

HARRISON WEST CONDOMINIUMS  
A PORTION OF LOT 2, BLOCK A, 'SOUTH AUDITORIUM ADDITION'  
SW1/4 SECTION 3, T.1S., R.1E., W.M.  
CITY OF PORTLAND  
MULTNOMAH COUNTY, OREGON  
SURVEYED NOVEMBER 23, 2005  
SHEET 1 OF 11

SURVEYOR'S BUILDING CERTIFICATE

I, GARY E. PAUL, REGISTERED PROFESSIONAL LAND SURVEYOR, DO HEREBY CERTIFY THAT I HAVE PERSONALLY EXAMINED THE SURVEY AND ACCURATELY DEPICTED THE BOUNDARIES OF THE UNITS AND OF THE BUILDINGS AND THAT I HAVE SEEN AND BUILT THE UNITS AND BUILDINGS, AS DEPICTED ON SAID PLAN, HAS BEEN COMPLETED.  
DATED THIS 25<sup>TH</sup> DAY OF APRIL, 2006.

GARY E. PAUL  
REGISTERED PROFESSIONAL LAND SURVEYOR NO. 2698

otak  
1205 S.W. BUNKER STREET, SUITE 4040  
LAKE OSWEGO, OREGON 97035  
(503)835-9419 FAX (503)835-3395

BOOK 1195, PAGE 51  
AUG. 31, 1976

TABLE OF CONTENTS

|          |   |
|----------|---|
| SHEET 1  | BOUNDARY SURVEYOR'S BUILDING CERTIFICATE BUILDING LOCATION  |
| SHEET 2  | LOWER GARAGE PLAN   |
| SHEET 3  | UPPER GARAGE PLAN   |
| SHEET 4  | FLOORS 1 AND 2 PLANS  |
| SHEET 5  | FLOORS 3-12 AND 14 PLANS                                    |
| SHEET 6  | FLOORS 15, 16 AND 17, 18 PLANS                              |
| SHEET 7  | FLOORS 19-23 AND 24-26 PLANS                                |
| SHEET 8  | TOWNHOME PLANS  |
| SHEET 9  | TOWNHOME PLAN AND SECTION BASEMENT AREA (OCE) PLAN          |
| SHEET 10 | BUILDING SECTION PARKING UNIT SECTION                       |
| SHEET 11 | APPROVALS NOTES AND RESTRICTIONS DECLARATION ACKNOWLEDGMENT |

SCALE: 1"=30'

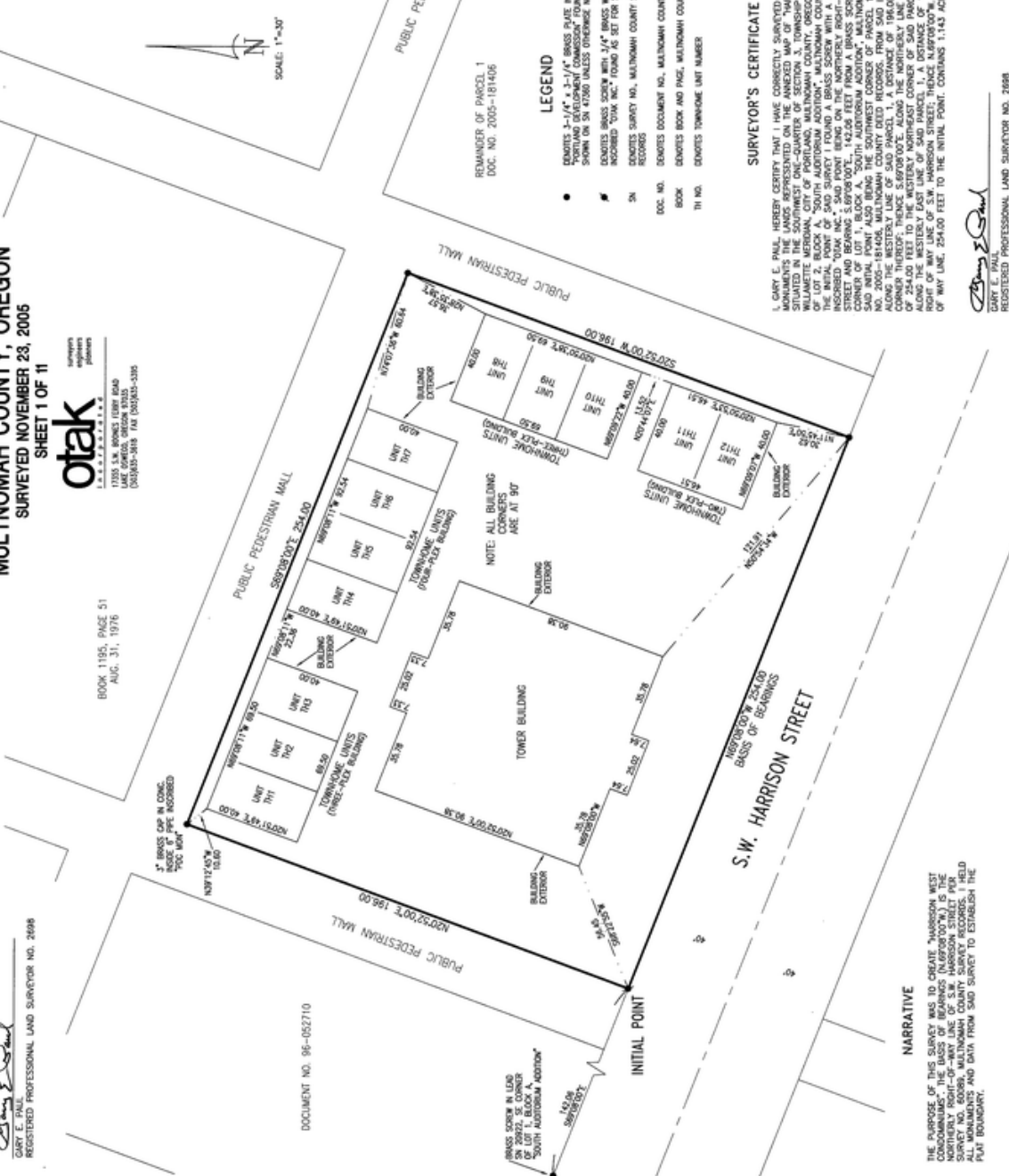

LEGEND

- DENOTES 3-1/4" x 3-1/4" BRASS PLATE INCORPORATED "PORTLAND DEVELOPMENT COMMISSION" FOUND AS SHOWN ON SA 41650 UNLESS OTHERWISE NOTED.
- DENOTES BRASS SCREW WITH 3/4" BRASS WASHER ATTACHED "YAK INC." FOUND AS SET FOR SA 6058A.
- SA DENOTES SURVEY NO., MULTNOMAH COUNTY SURVEY RECORDS.
- DOC NO. DENOTES DOCUMENT NO., MULTNOMAH COUNTY RECORDS.
- BOOK DENOTES BOOK AND PAGE, MULTNOMAH COUNTY RECORDS.
- TH NO. DENOTES TOWNHOME UNIT NUMBER.

SURVEYOR'S CERTIFICATE

I, GARY E. PAUL, HEREBY CERTIFY THAT I HAVE CORRECTLY SURVEYED AND MARKED WITH PROPER SURVEY INSTRUMENTS AND PROCEDURES THE "HARRISON WEST CONDOMINIUMS", SITUATED IN THE SOUTHWEST ONE-QUARTER OF SECTION 3, TOWNSHIP 1 SOUTH, RANGE 1 EAST, WILLAMETTE MERIDIAN, CITY OF PORTLAND, MULTNOMAH COUNTY, OREGON, SAID LAND BEING A PORTION OF THE LOT 2, BLOCK A, "SOUTH AUDITORIUM ADDITION" MULTNOMAH COUNTY PLAT RECORDS, THAT AT THE TIME OF SA SURVEY SAID ADDITION WAS UNDEVELOPED AND UNOCCUPIED AND SAID ADDITION WAS INCORPORATED INTO SA "SOUTH AUDITORIUM ADDITION" MULTNOMAH COUNTY PLAT RECORDS. SAID INITIAL POINT ALSO BEING ON THE NORTHERLY RIGHT-OF-WAY LINE OF S.W. HARRISON STREET AND BEARING S.86°09'00" E., 142.00 FEET FROM A BRASS SCREW FOUND AT THE SOUTHEAST CORNER OF SA PARCEL 1. SA "SOUTH AUDITORIUM ADDITION" MULTNOMAH COUNTY PLAT RECORDS SAID INITIAL POINT ALSO BEING THE SOUTHWEST CORNER OF PARCEL NO. 60098 MULTNOMAH COUNTY SURVEY NO. 2005-181408, MULTNOMAH COUNTY RECORDS. FROM SAID INITIAL POINT I RAN A 320'52.00" LINE ALONG THE WESTERLY LINE OF SAID PARCEL 1, A DISTANCE OF 196.00 FEET TO THE NORTHWEST CORNER OF SA PARCEL 1. I RAN A 320'52.00" LINE ALONG THE WESTERLY LINE OF SAID PARCEL 1, A DISTANCE OF 254.00 FEET TO THE NORTHERLY CORNER OF SA PARCEL 1. I RAN A 320'52.00" LINE ALONG THE WESTERLY EAST LINE OF SAID PARCEL 1, A DISTANCE OF 196.00 FEET TO THE NORTHERLY CORNER OF SA PARCEL 1. I RAN A 320'52.00" LINE ALONG THE WESTERLY EAST LINE OF SAID PARCEL 1, A DISTANCE OF 254.00 FEET TO THE NORTHERLY CORNER OF SA PARCEL 1. I RAN A 320'52.00" LINE ALONG THE WESTERLY EAST LINE OF SAID PARCEL 1, A DISTANCE OF 196.00 FEET TO THE NORTHERLY CORNER OF SA PARCEL 1. I RAN A 320'52.00" LINE ALONG THE WESTERLY EAST LINE OF SAID PARCEL 1, A DISTANCE OF 196.00 FEET TO THE NORTHERLY CORNER OF SA PARCEL 1.

NARRATIVE

THE PURPOSE OF THIS SURVEY WAS TO CREATE "HARRISON WEST CONDOMINIUMS" SITUATED IN THE SOUTHWEST ONE-QUARTER OF SECTION 3, TOWNSHIP 1 SOUTH, RANGE 1 EAST, WILLAMETTE MERIDIAN, CITY OF PORTLAND, MULTNOMAH COUNTY, OREGON, SAID LAND BEING A PORTION OF THE LOT 2, BLOCK A, "SOUTH AUDITORIUM ADDITION" MULTNOMAH COUNTY PLAT RECORDS, THAT AT THE TIME OF SA SURVEY SAID ADDITION WAS UNDEVELOPED AND UNOCCUPIED AND SAID ADDITION WAS INCORPORATED INTO SA "SOUTH AUDITORIUM ADDITION" MULTNOMAH COUNTY PLAT RECORDS. SAID INITIAL POINT ALSO BEING ON THE NORTHERLY RIGHT-OF-WAY LINE OF S.W. HARRISON STREET AND BEARING S.86°09'00" E., 142.00 FEET FROM A BRASS SCREW FOUND AT THE SOUTHEAST CORNER OF SA PARCEL 1. SA "SOUTH AUDITORIUM ADDITION" MULTNOMAH COUNTY PLAT RECORDS SAID INITIAL POINT ALSO BEING THE SOUTHWEST CORNER OF PARCEL NO. 60098 MULTNOMAH COUNTY SURVEY NO. 2005-181408, MULTNOMAH COUNTY RECORDS. FROM SAID INITIAL POINT I RAN A 320'52.00" LINE ALONG THE WESTERLY LINE OF SAID PARCEL 1, A DISTANCE OF 196.00 FEET TO THE NORTHWEST CORNER OF SA PARCEL 1. I RAN A 320'52.00" LINE ALONG THE WESTERLY EAST LINE OF SAID PARCEL 1, A DISTANCE OF 254.00 FEET TO THE NORTHERLY CORNER OF SA PARCEL 1. I RAN A 320'52.00" LINE ALONG THE WESTERLY EAST LINE OF SAID PARCEL 1, A DISTANCE OF 196.00 FEET TO THE NORTHERLY CORNER OF SA PARCEL 1. I RAN A 320'52.00" LINE ALONG THE WESTERLY EAST LINE OF SAID PARCEL 1, A DISTANCE OF 196.00 FEET TO THE NORTHERLY CORNER OF SA PARCEL 1.

GARY E. PAUL  
REGISTERED PROFESSIONAL LAND SURVEYOR NO. 2698

REGISTERED PROFESSIONAL LAND SURVEYOR  
GARY E. PAUL  
JANUARY 6, 1993  
PLS. NO. 2008

THIS IS AN EXACT COPY OF THE ORIGINAL PLAT "HARRISON WEST CONDOMINIUMS".

# HARRISON WEST CONDOMINIUMS

A PORTION OF LOT 2, BLOCK A, "SOUTH AUDITORIUM ADDITION"  
 SW1/4 SECTION 3, T.1S., R.1E., W.M.  
 CITY OF PORTLAND  
 MULTNOMAH COUNTY, OREGON  
 SURVEYED NOVEMBER 23, 2005  
 SHEET 2 OF 11

**LEGEND**

GCE DENOTES GENERAL COMMON ELEMENT  
 P. NO. DENOTES PARKING UNIT NUMBER

NOTE: SEE SHEET 10 FOR BUILDING SECTION  
 A-A AND PARKING UNIT SECTION B-B.

ALL UNIT AND COMMON ELEMENT  
 DIMENSIONS ARE IN FEET  
 UNLESS OTHERWISE NOTED.

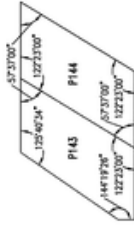

| UNIT NO.   | ELEV.  |
|------------|--------|
| P81        | 102.00 |
| P82        | 102.00 |
| P83-P91    | 103.00 |
| P92-P93    | 103.94 |
| P94-P95    | 103.90 |
| P96-P97    | 98.42  |
| P98-P105   | 98.35  |
| P106, P107 | 98.38  |
| P108       | 98.48  |
| P109-P119  | 98.50  |
| P120-P125  | 98.40  |
| P126-P132  | 98.39  |
| P133-P134  | 98.39  |
| P135       | 98.44  |
| P136-P144  | 98.48  |
| P145-P174  | 103.42 |

REGISTERED PROFESSIONAL LAND SURVEYOR  
 JAMES GARY E. PAUL  
 OREGON LICENSE NO. 2698  
 12/31/2006  
 THIS IS AN EXACT COPY OF THE ORIGINAL SURVEY MAP FOR "HARRISON WEST CONDOMINIUMS".  
 GARY E. PAUL  
 P.L.S. NO. 2698

| UNIT NO.   | AREA     | UNIT NO. | AREA     |
|------------|----------|----------|----------|
| P81        | 154 S.F. | P143     | 135 S.F. |
| P82        | 145 S.F. | P144     | 138 S.F. |
| P83        | 222 S.F. | P145     | 146 S.F. |
| P84        | 212 S.F. | P146     | 140 S.F. |
| P85        | 224 S.F. | P147     | 141 S.F. |
| P86        | 211 S.F. | P148     | 136 S.F. |
| P87        | 263 S.F. | P149     | 143 S.F. |
| P88        | 211 S.F. | P150     | 148 S.F. |
| P89        | 224 S.F. | P151     | 146 S.F. |
| P90        | 224 S.F. | P152     | 146 S.F. |
| P91        | 224 S.F. | P153     | 135 S.F. |
| P92        | 224 S.F. | P154     | 133 S.F. |
| P93        | 211 S.F. |          |          |
| P94        | 145 S.F. |          |          |
| P95        | 140 S.F. |          |          |
| P96        | 243 S.F. |          |          |
| P97        | 215 S.F. |          |          |
| P98        | 223 S.F. |          |          |
| P99        | 223 S.F. |          |          |
| P100       | 258 S.F. |          |          |
| P101       | 198 S.F. |          |          |
| P102       | 138 S.F. |          |          |
| P103       | 137 S.F. |          |          |
| P104       | 237 S.F. |          |          |
| P105       | 208 S.F. |          |          |
| P106       | 208 S.F. |          |          |
| P107       | 178 S.F. |          |          |
| P108       | 192 S.F. |          |          |
| P109       | 128 S.F. |          |          |
| P110, P111 | 134 S.F. |          |          |
| P112       | 137 S.F. |          |          |
| P113, P114 | 135 S.F. |          |          |
| P115, P116 | 136 S.F. |          |          |
| P117       | 134 S.F. |          |          |
| P118       | 137 S.F. |          |          |
| P119       | 134 S.F. |          |          |
| P120       | 205 S.F. |          |          |
| P121       | 208 S.F. |          |          |
| P122       | 179 S.F. |          |          |
| P123       | 178 S.F. |          |          |
| P124       | 102 S.F. |          |          |
| P125       | 109 S.F. |          |          |
| P126       | 106 S.F. |          |          |
| P127       | 230 S.F. |          |          |
| P128       | 228 S.F. |          |          |
| P129       | 180 S.F. |          |          |
| P130       | 134 S.F. |          |          |
| P131       | 238 S.F. |          |          |
| P132       | 193 S.F. |          |          |
| P133       | 238 S.F. |          |          |
| P134       | 238 S.F. |          |          |
| P135       | 191 S.F. |          |          |
| P136       | 194 S.F. |          |          |
| P137       | 240 S.F. |          |          |
| P138       | 199 S.F. |          |          |
| P139       | 199 S.F. |          |          |
| P140       | 227 S.F. |          |          |
| P141       | 239 S.F. |          |          |
| P142       | 139 S.F. |          |          |
| P143       | 137 S.F. |          |          |
| P144       | 240 S.F. |          |          |
| P145       | 194 S.F. |          |          |
| P146       | 190 S.F. |          |          |
| P147       | 238 S.F. |          |          |
| P148       | 238 S.F. |          |          |
| P149       | 199 S.F. |          |          |
| P150       | 197 S.F. |          |          |
| P151       | 234 S.F. |          |          |
| P152       | 198 S.F. |          |          |
| P153       | 198 S.F. |          |          |
| P154       | 198 S.F. |          |          |
| P155       | 194 S.F. |          |          |
| P156       | 138 S.F. |          |          |
| P157       | 134 S.F. |          |          |
| P158       | 135 S.F. |          |          |
| P159       | 137 S.F. |          |          |
| P160       | 136 S.F. |          |          |
| P161       | 128 S.F. |          |          |
| P162       | 143 S.F. |          |          |

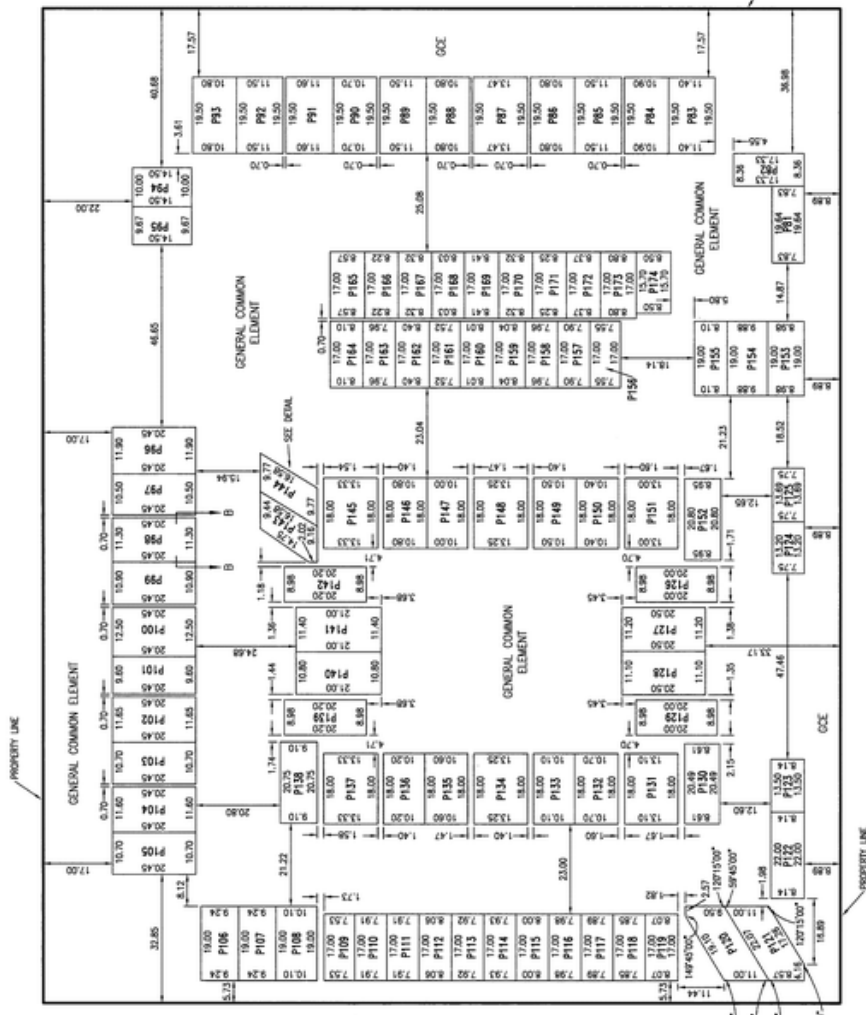

GARAGE LOWER LEVEL PLAN  
 SCALE: 1"=20'

# HARRISON WEST CONDOMINIUMS

A PORTION OF LOT 2, BLOCK A, "SOUTH AUDITORIUM ADDITION"  
SW1/4 SECTION 3, T.1S., R.1E., W.M.  
CITY OF PORTLAND  
MULTNOMAH COUNTY, OREGON  
SURVEYED NOVEMBER 23, 2005  
SHEET 3 OF 11

### LEGEND

- GCE DENOTES GENERAL COMMON ELEMENT
- P NO. DENOTES PARKING UNIT NUMBER

NOTE: SEE SHEET 10 FOR BUILDING SECTION A-A AND PARKING UNIT SECTION B-B.  
ALL UNIT AND COMMON ELEMENT BOUNDARIES ARE AT 90° UNLESS OTHERWISE NOTED.



| UNIT NO. | AREA     | UNIT NO. | AREA     |
|----------|----------|----------|----------|
| P1       | 131 S.F. | P84      | 165 S.F. |
| P2       | 135 S.F. | P85      | 212 S.F. |
| P3       | 134 S.F. | P86      | 234 S.F. |
| P4       | 131 S.F. | P87      | 168 S.F. |
| P5       | 136 S.F. | P88      | 152 S.F. |
| P6       | 130 S.F. | P89      | 134 S.F. |
| P7       | 134 S.F. | P90      | 138 S.F. |
| P8       | 138 S.F. | P91      | 128 S.F. |
| P9       | 141 S.F. | P92      | 132 S.F. |
| P10      | 137 S.F. | P93      | 135 S.F. |
| P11      | 137 S.F. | P94      | 135 S.F. |
| P12      | 137 S.F. | P95      | 135 S.F. |
| P13      | 137 S.F. | P96      | 135 S.F. |
| P14      | 218 S.F. | P97      | 148 S.F. |
| P15      | 230 S.F. | P98      | 158 S.F. |
| P16      | 229 S.F. | P99      | 160 S.F. |
| P17      | 231 S.F. | P100     | 155 S.F. |
| P18      | 221 S.F. |          |          |
| P19      | 225 S.F. |          |          |
| P20      | 225 S.F. |          |          |
| P21      | 231 S.F. |          |          |
| P22      | 225 S.F. |          |          |
| P23      | 225 S.F. |          |          |
| P24      | 208 S.F. |          |          |
| P25      | 171 S.F. |          |          |
| P26      | 207 S.F. |          |          |
| P27      | 133 S.F. |          |          |
| P28      | 131 S.F. |          |          |
| P29      | 137 S.F. |          |          |
| P30      | 137 S.F. |          |          |
| P31      | 137 S.F. |          |          |
| P32      | 132 S.F. |          |          |
| P33      | 136 S.F. |          |          |
| P34      | 131 S.F. |          |          |
| P35      | 135 S.F. |          |          |
| P36      | 134 S.F. |          |          |
| P37      | 134 S.F. |          |          |
| P38      | 133 S.F. |          |          |
| P39      | 133 S.F. |          |          |
| P40      | 133 S.F. |          |          |
| P41      | 133 S.F. |          |          |
| P42      | 99 S.F.  |          |          |
| P43      | 160 S.F. |          |          |
| P44      | 228 S.F. |          |          |
| P45      | 228 S.F. |          |          |
| P46      | 185 S.F. |          |          |
| P47      | 185 S.F. |          |          |
| P48      | 234 S.F. |          |          |
| P49      | 185 S.F. |          |          |
| P50      | 185 S.F. |          |          |
| P51      | 185 S.F. |          |          |
| P52      | 185 S.F. |          |          |
| P53      | 182 S.F. |          |          |
| P54      | 238 S.F. |          |          |
| P55      | 191 S.F. |          |          |
| P56      | 191 S.F. |          |          |
| P57      | 205 S.F. |          |          |
| P58      | 181 S.F. |          |          |
| P59      | 171 S.F. |          |          |
| P60      | 171 S.F. |          |          |
| P61      | 218 S.F. |          |          |
| P62      | 218 S.F. |          |          |
| P63      | 238 S.F. |          |          |

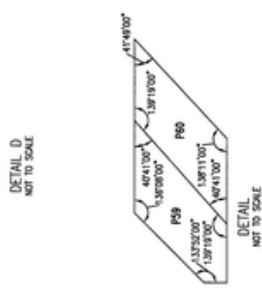

| UNIT NO. | ELEV.  |
|----------|--------|
| P1       | 114.00 |
| P2       | 114.11 |
| P3       | 114.11 |
| P4       | 114.11 |
| P5       | 108.82 |
| P6       | 108.82 |
| P7       | 108.82 |
| P8       | 108.82 |
| P9       | 108.82 |
| P10      | 108.82 |
| P11      | 108.82 |
| P12      | 108.82 |
| P13      | 108.82 |
| P14      | 108.82 |
| P15      | 108.82 |
| P16      | 108.82 |
| P17      | 108.82 |
| P18      | 108.82 |
| P19      | 108.82 |
| P20      | 108.82 |
| P21      | 108.82 |
| P22      | 108.82 |
| P23      | 108.82 |
| P24      | 108.82 |
| P25      | 108.82 |
| P26      | 108.82 |
| P27      | 108.82 |
| P28      | 108.82 |
| P29      | 108.82 |
| P30      | 108.82 |
| P31      | 108.82 |
| P32      | 108.82 |
| P33      | 108.82 |
| P34      | 108.82 |
| P35      | 108.82 |
| P36      | 108.82 |
| P37      | 108.82 |
| P38      | 108.82 |
| P39      | 108.82 |
| P40      | 108.82 |
| P41      | 108.82 |
| P42      | 108.82 |
| P43      | 108.82 |
| P44      | 108.82 |
| P45      | 108.82 |
| P46      | 108.82 |
| P47      | 108.82 |
| P48      | 108.82 |
| P49      | 108.82 |
| P50      | 108.82 |
| P51      | 108.82 |
| P52      | 108.82 |
| P53      | 108.82 |
| P54      | 108.82 |
| P55      | 108.82 |
| P56      | 108.82 |
| P57      | 108.82 |
| P58      | 108.82 |
| P59      | 108.82 |
| P60      | 108.82 |

REGISTERED PROFESSIONAL LAND SURVEYOR  
*Gary E. Paul*  
OREGON LAND SURVEYORS BOARD  
GARY E. PAUL  
2688  
RENEWAL 12/31/2008  
THIS IS AN EXACT COPY OF THE ORIGINAL PLAT, HARRISON WEST CONDOMINIUMS.  
*Gary E. Paul*  
P.L.S. NO. 2688

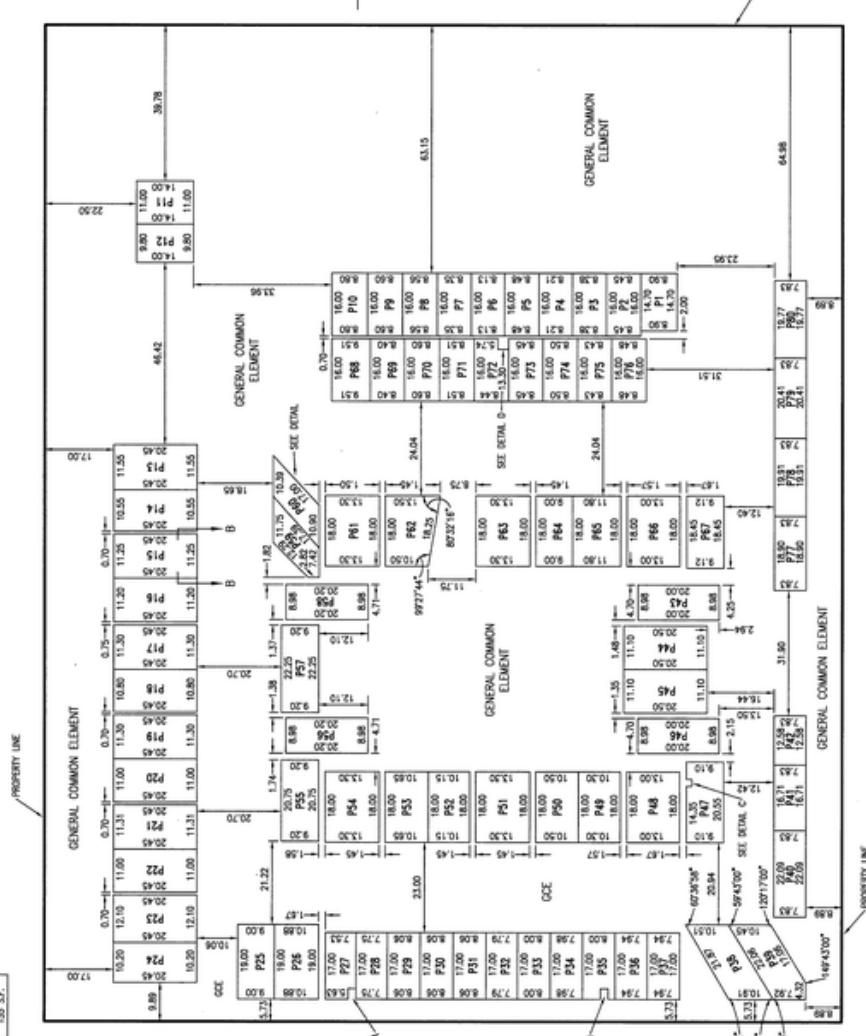

GARAGE UPPER LEVEL PLAN  
SCALE: 1"=20'

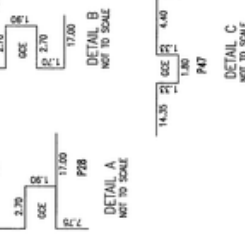

# HARRISON WEST CONDOMINIUMS

A PORTION OF LOT 2, BLOCK A, "SOUTH AUDITORIUM ADDITION"  
SW1/4 SECTION 3, T.1S., R.1E., W.M.  
CITY OF PORTLAND  
MULTNOMAH COUNTY, OREGON  
SURVEYED NOVEMBER 23, 2005  
SHEET 4 OF 11

### LEGEND

- GCE DENOTES GENERAL COMMON ELEMENT
- LCE DENOTES LIMITED COMMON ELEMENT
- S.F. SQUARE FEET

NOTE: SEE SHEET 10 FOR BUILDING SECTION A-A AND UNIT ELEVATIONS.

ALL UNIT AND COMMON ELEMENT DIMENSIONS ARE IN FEET UNLESS OTHERWISE NOTED.

REGISTERED PROFESSIONAL LAND SURVEYOR  
GARY E. PAUL  
JANUARY 17, 1984  
EXPIRES 12/31/2008  
BIRTHDAY 12/17/1958  
THIS IS AN EXACT COPY OF THE ORIGINAL P.L.A.T. "HARRISON WEST CONDOMINIUMS".  
P.L.S. NO. 2698

**otak**  
surveyors  
engineers  
planners  
11700 S.W. BONDES FERRY ROAD  
LAKE OREGON, OREGON 97035  
(503)552-5818 FAX (503)552-5855

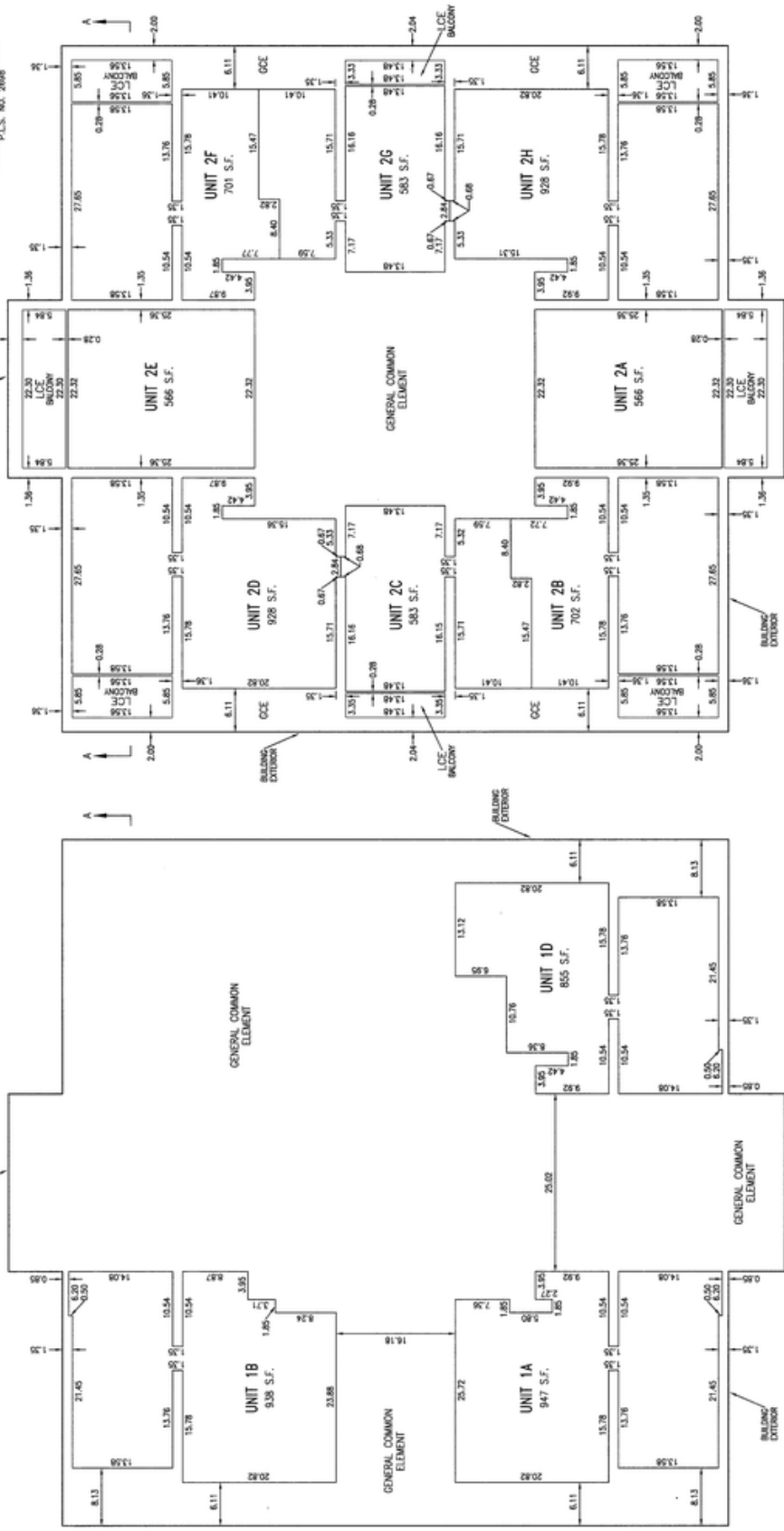

TOWER BUILDING - FLOOR 1 PLAN  
SCALE: 1"=10'

TOWER BUILDING - FLOOR 2 PLAN  
SCALE: 1"=10'

# HARRISON WEST CONDOMINIUMS

A PORTION OF LOT 2, BLOCK A, "SOUTH AUDITORIUM ADDITION"  
 SW1/4 SECTION 3, T.1S., R.1E., W.M.  
 CITY OF PORTLAND  
 MULTNOMAH COUNTY, OREGON  
 SURVEYED NOVEMBER 23, 2005  
 SHEET 5 OF 11

## UNIT NUMBERING

| FLOOR | UNIT A | UNIT B | UNIT C | UNIT D | UNIT E | UNIT F | UNIT G | UNIT H |
|-------|--------|--------|--------|--------|--------|--------|--------|--------|
| 3     | 3A     | 3B     | 3C     | 3D     | 3E     | 3F     | 3G     | 3H     |
| 4     | 4A     | 4B     | 4C     | 4D     | 4E     | 4F     | 4G     | 4H     |
| 5     | 5A     | 5B     | 5C     | 5D     | 5E     | 5F     | 5G     | 5H     |
| 6     | 6A     | 6B     | 6C     | 6D     | 6E     | 6F     | 6G     | 6H     |
| 7     | 7A     | 7B     | 7C     | 7D     | 7E     | 7F     | 7G     | 7H     |
| 8     | 8A     | 8B     | 8C     | 8D     | 8E     | 8F     | 8G     | 8H     |
| 9     | 9A     | 9B     | 9C     | 9D     | 9E     | 9F     | 9G     | 9H     |
| 10    | 10A    | 10B    | 10C    | 10D    | 10E    | 10F    | 10G    | 10H    |
| 11    | 11A    | 11B    | 11C    | 11D    | 11E    | 11F    | 11G    | 11H    |
| 12    | 12A    | 12B    | 12C    | 12D    | 12E    | 12F    | 12G    | 12H    |

LEGEND  
 GCE DENOTES GENERAL COMMON ELEMENT  
 LCE DENOTES LIMITED COMMON ELEMENT  
 S.F. SQUARE FEET

NOTE: SEE SHEET 10 FOR BUILDING SECTION  
 A-A AND UNIT ELEVATIONS.

ALL UNIT AND COMMON ELEMENT  
 BOUNDARIES ARE AT 90°  
 UNLESS OTHERWISE NOTED.

REGISTERED PROFESSIONAL  
 LAND SURVEYOR  
 OREGON  
 JANUARY 9, 1985  
 GARY E. PAUL  
 2885  
 EXPIRES 12/31/2008  
 THIS IS AN EXACT COPY OF  
 THE ORIGINAL SURVEY FOR  
 "HARRISON WEST CONDOMINIUMS".  
 P.L.S. NO. 2098

**otak**  
 OREGON TITLE & LAND SURVEYING, INC.  
 1274 S.W. ROSS STREET, SUITE 200  
 PORTLAND, OREGON 97205  
 (503)433-5415 FAX (503)433-5395

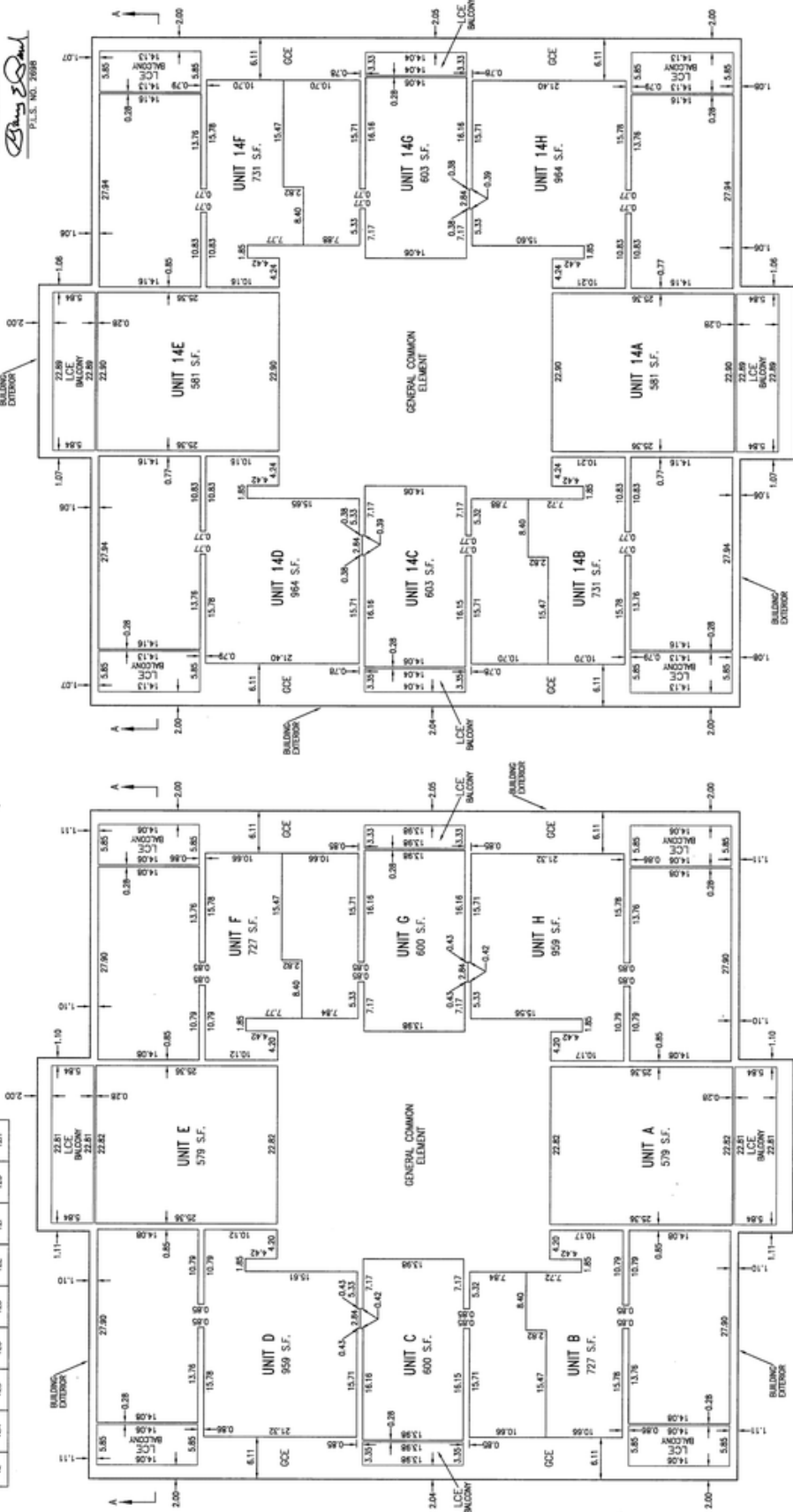

NOTE: THERE IS NO 13TH FLOOR  
 WITHIN THE TOWER BUILDING

TOWER BUILDING - FLOOR 14 PLAN  
 SCALE: 1"=10'

TOWER BUILDING - FLOORS 3-12 PLAN  
 SCALE: 1"=10'

# HARRISON WEST CONDOMINIUMS

A PORTION OF LOT 2, BLOCK A, "SOUTH AUDITORIUM ADDITION"  
 SW1/4 SECTION 3, T.1S., R.1E., W.M.  
 CITY OF PORTLAND  
 MULTNOMAH COUNTY, OREGON  
 SURVEYED NOVEMBER 23, 2005  
 SHEET 8 OF 11

REGISTERED PROFESSIONAL LAND SURVEYOR  
 OREGON  
 JANUARY 10, 1989  
 GARY PAUL  
 2005  
 EXPIRES 12/31/2006  
 THE ORIGINAL PLAN HARRISON WEST CONDOMINIUMS  
 P.L.S. NO. 2008

**otak**  
 11333 S.W. BONDE FERRY ROAD  
 LAKE OREGON, OREGON 97035  
 (503)335-3811 FAX (503)335-3390

**LEGEND**  
 GCE DENOTES GENERAL COMMON ELEMENT  
 LCE DENOTES LIMITED COMMON ELEMENT  
 S.F. SQUARE FEET  
 NOTE: SEE SHEET 10 FOR BUILDING SECTION  
 A-A AND UNIT ELEVATIONS.  
 ALL UNIT AND COMMON ELEMENT  
 BOUNDARIES ARE AT 90°  
 UNLESS OTHERWISE NOTED.

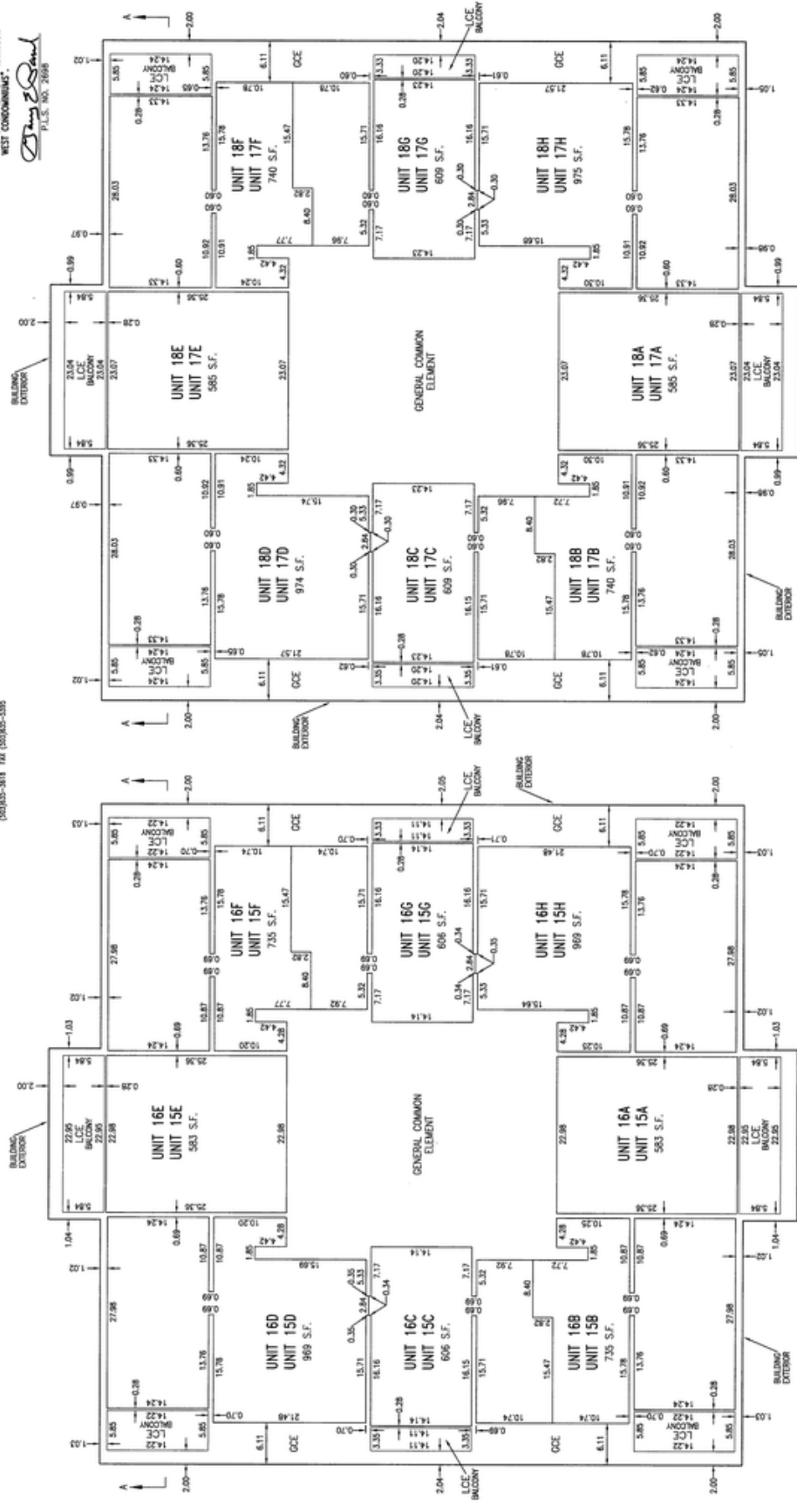

TOWER BUILDING - FLOORS 17, 18 PLAN  
 SCALE: 1"=10'

TOWER BUILDING - FLOORS 15, 16 PLAN  
 SCALE: 1"=10'

**HARRISON WEST CONDOMINIUMS**  
 A PORTION OF LOT 2, BLOCK A, 'SOUTH AUDITORIUM ADDITION'  
 SW1/4 SECTION 3, T.1S., R.1E., W.M.  
 CITY OF PORTLAND  
 MULTNOMAH COUNTY, OREGON  
 SURVEYED NOVEMBER 23, 2005  
 SHEET 7 OF 11

**UNIT NUMBERING**

| FLOOR | UNIT A | UNIT B | UNIT C | UNIT D | UNIT E | UNIT F | UNIT G | UNIT H |
|-------|--------|--------|--------|--------|--------|--------|--------|--------|
| 19    | 19A    | 19B    | 19C    | 19D    | 19E    | 19F    | 19G    | 19H    |
| 20    | 20A    | 20B    | 20C    | 20D    | 20E    | 20F    | 20G    | 20H    |
| 21    | 21A    | 21B    | 21C    | 21D    | 21E    | 21F    | 21G    | 21H    |
| 22    | 22A    | 22B    | 22C    | 22D    | 22E    | 22F    | 22G    | 22H    |
| 23    | 23A    | 23B    | 23C    | 23D    | 23E    | 23F    | 23G    | 23H    |
| 24    | 24A    | 24B    | 24C    | 24D    | X      | X      | X      | X      |
| 25    | 25A    | 25B    | 25C    | 25D    | X      | X      | X      | X      |
| 26    | 26A    | 26B    | 26C    | 26D    | X      | X      | X      | X      |

**LEGEND**

GCE DENOTES GENERAL COMMON ELEMENT  
 LCE DENOTES LIMITED COMMON ELEMENT  
 S.F. SQUARE FEET

NOTE: SEE SHEET 10 FOR BUILDING SECTION A-A AND UNIT ELEVATIONS.  
 ALL UNIT AND COMMON ELEMENT BOUNDARIES ARE AT 5/8" UNLESS OTHERWISE NOTED.

REGISTERED PROFESSIONAL LAND SURVEYOR  
 GARY E. PAUL  
 FEDERAL 12/31/2006  
 THE OFFICE OF GARY E. PAUL IS LOCATED AT 1000 SW 10TH AVENUE, SUITE 200, PORTLAND, OREGON 97205  
 P.L.S. NO. 2008

**otak**  
 ARCHITECTS  
 1133 S.W. BOWEN STREET, SUITE 200  
 PORTLAND, OREGON 97205  
 (503)525-3811 FAX (503)525-3285

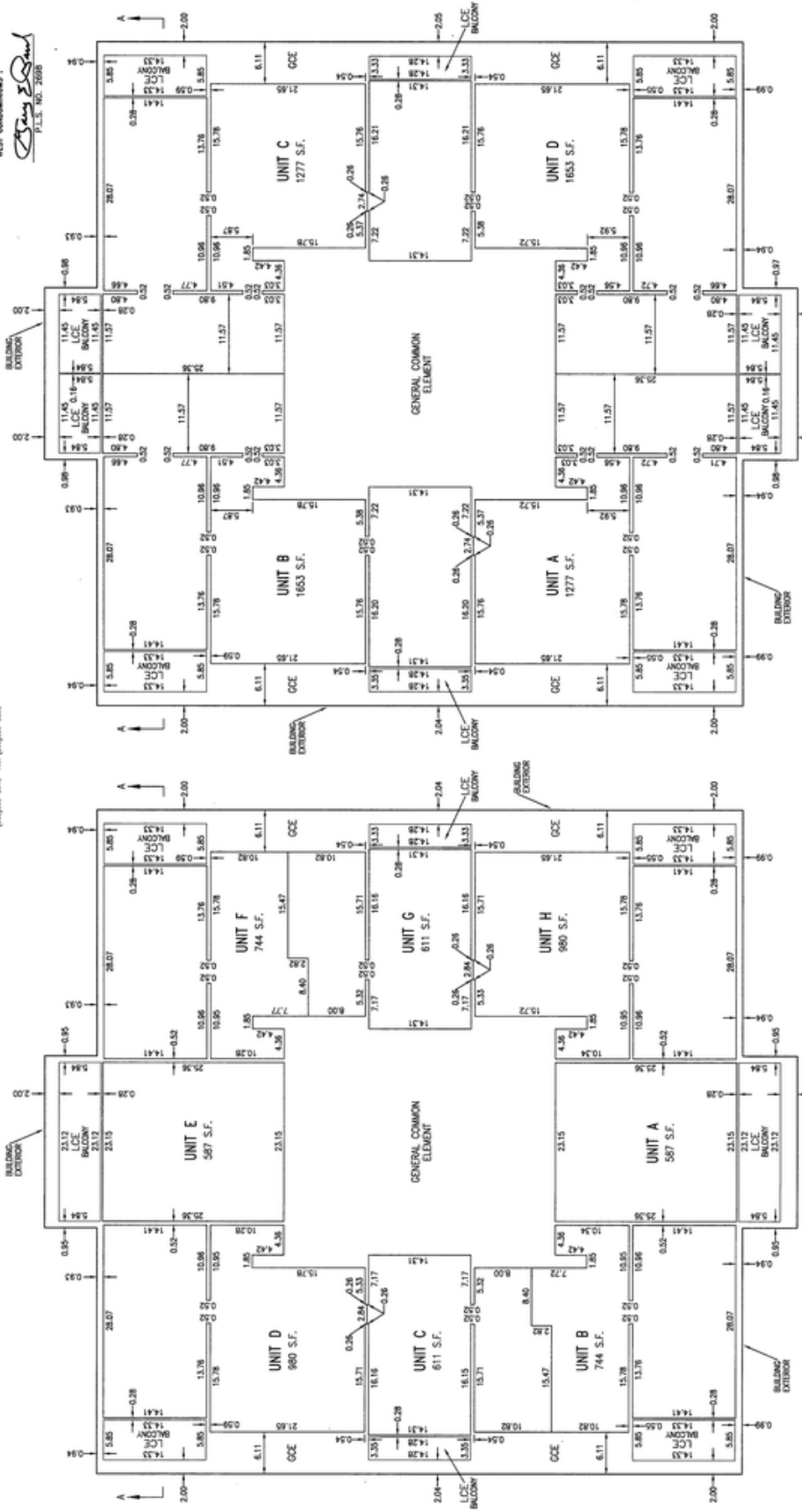

TOWER BUILDING - FLOORS 24-26 PLAN  
 SCALE: 1"=10'

TOWER BUILDING - FLOORS 19-23 PLAN  
 SCALE: 1"=10'

# HARRISON WEST CONDOMINIUMS

A PORTION OF LOT 2, BLOCK A, "SOUTH AUDITORIUM ADDITION"  
 SW1/4 SECTION 3, T.1S., R.1E., W.M.  
 CITY OF PORTLAND  
 MULTNOMAH COUNTY, OREGON  
 SURVEYED NOVEMBER 23, 2005  
 SHEET 8 OF 11

**LEGEND**  
 GCE DENOTES GENERAL COMMON ELEMENT  
 LCE DENOTES LIMITED COMMON ELEMENT  
 S.F. SQUARE FEET  
 TH NO. DENOTES TOWNHOME UNIT NUMBER

NOTE: SEE SHEET 9 FOR TOWNHOME SECTION  
 C-C AND UNIT ELEVATIONS.  
 ALL UNIT AND COMMON ELEMENT  
 BOUNDARIES ARE AT 90°  
 UNLESS OTHERWISE NOTED.

**otak**  
 OREGON TITLE AND CONSTRUCTION  
 11700 S.W. BOYD STREET, SUITE 200  
 PORTLAND, OREGON 97205  
 (503) 253-3818 FAX (503) 253-5185

REGISTERED PROFESSIONAL LAND SURVEYOR  
 OREGON  
 JANUARY 11, 1999  
 GARY E. PAUL  
 2006

REGISTERED PROFESSIONAL LAND SURVEYOR  
 OREGON  
 JANUARY 11, 1999  
 GARY E. PAUL  
 2006

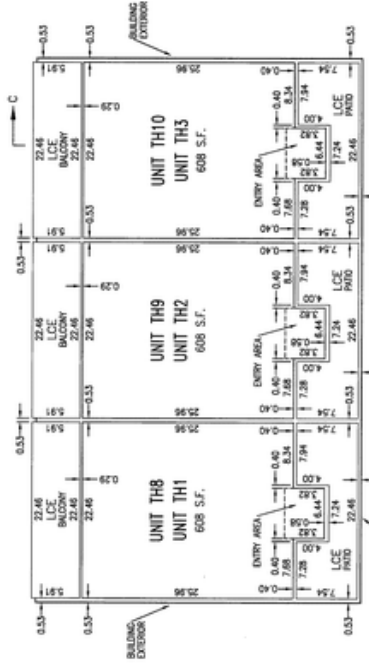

TOWNHOME (THREE-PLEX) UPPER LEVEL  
 SCALE: 1"=10'

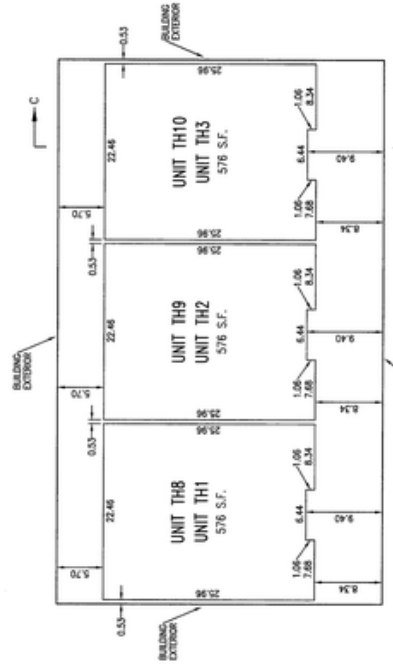

TOWNHOME (THREE-PLEX) LOWER LEVEL  
 SCALE: 1"=10'

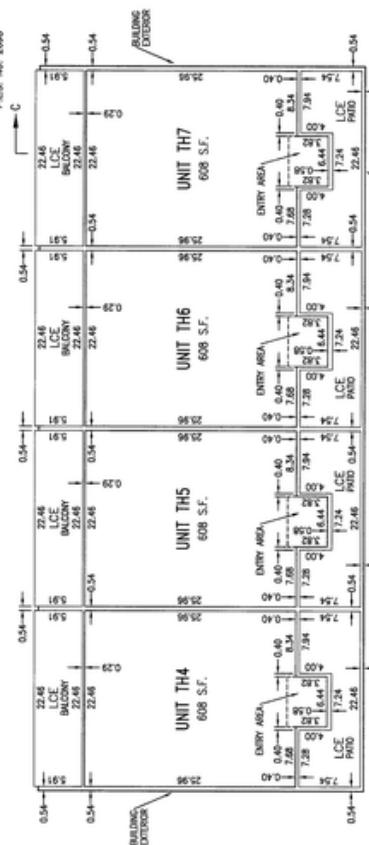

TOWNHOME (FOUR-PLEX) UPPER LEVEL  
 SCALE: 1"=10'

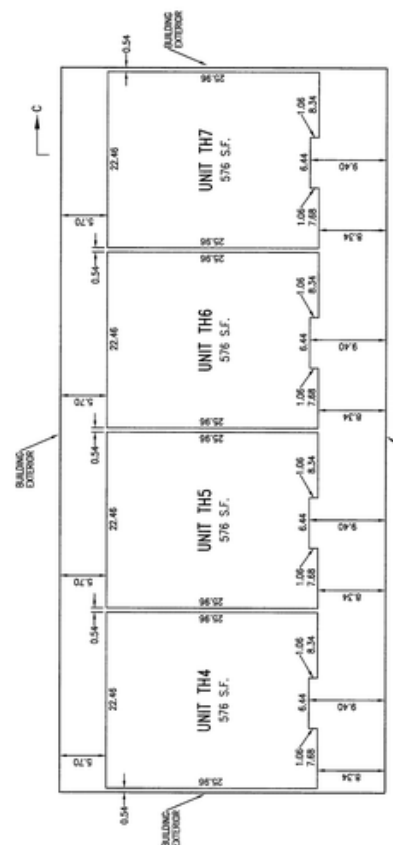

TOWNHOME (FOUR-PLEX) LOWER LEVEL  
 SCALE: 1"=10'



**HARRISON WEST CONDOMINIUMS**  
 A PORTION OF LOT 2, BLOCK A, "SOUTH AUDITORIUM ADDITION"  
 SW1/4 SECTION 3, T.1S., R.1E., W.M.  
 CITY OF PORTLAND  
 MULTNOMAH COUNTY, OREGON  
 SURVEYED NOVEMBER 23, 2005  
 SHEET 8 OF 11

**otak**  
 LAND SURVEYORS  
 1138 S.W. BOWEN STREET, SUITE 200  
 PORTLAND, OREGON 97205  
 (503)555-5818 FAX (503)555-5185

**LEGEND**  
 GCE DENOTES GENERAL COMMON ELEMENT  
 LCE DENOTES LIMITED COMMON ELEMENT  
 S.F. SQUARE FEET  
 TH NO. DENOTES TOWNHOME UNIT NUMBER

**NOTE:** ALL UNIT AND COMMON ELEMENT BOUNDARIES ARE AT 90° UNLESS OTHERWISE NOTED.

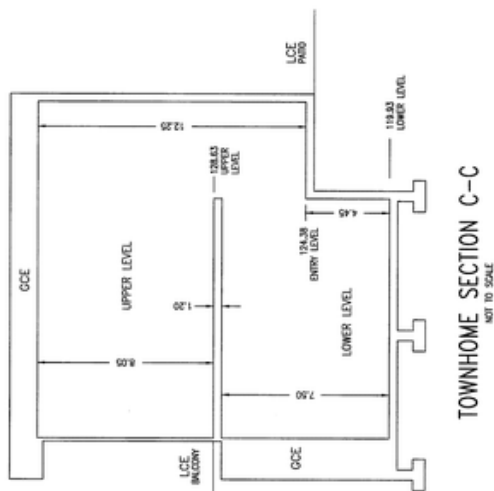
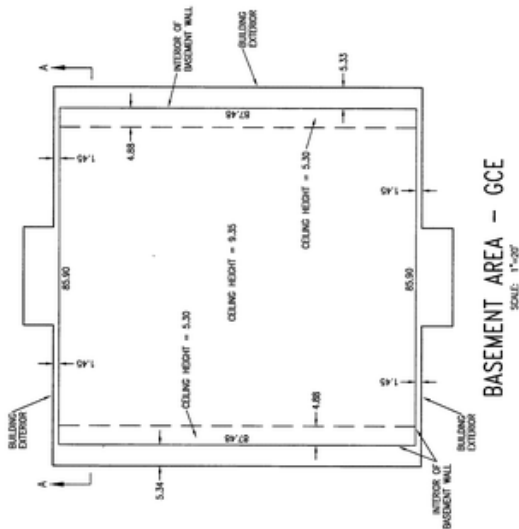
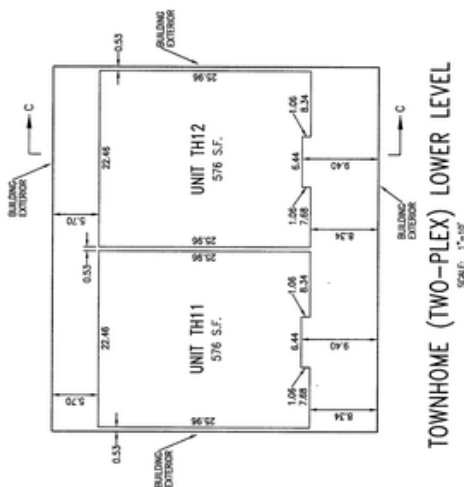
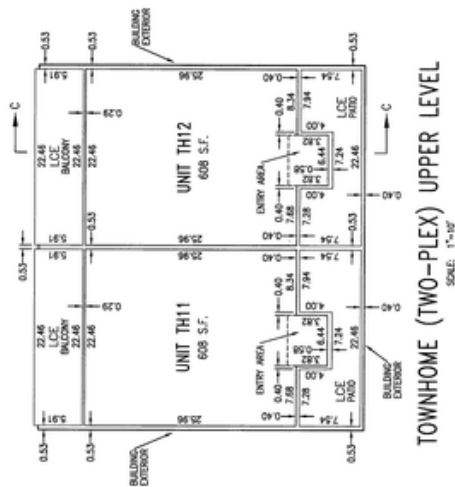

TOWNHOME SECTION AND ELEVATIONS ARE TYPICAL FOR ALL TOWNHOME BUILDINGS  
 BASES OF ELEVATIONS: CITY OF PORTLAND BENCH 3100, A 2-1/2" BRASS  
 GCS IN THE EAST END OF CONCRETE ISLAND ON THE APPROXIMATE CENTRLINE  
 OF S.W. BOWEN STREET, PORTLAND, OREGON, WITH 3.6" 1ST AVENUE  
 ELEVATION = 121.302', CITY OF PORTLAND DATUM.

REGISTERED  
**PROFESSIONAL  
 LAND SURVEYOR**  
 OREGON  
 EXPIRES 12/31/2008  
 ANTHONY J. SQUADRA  
 GARY J. PAUL  
 P.L.L.C. NO. 2098

# HARRISON WEST CONDOMINIUMS

A PORTION OF LOT 2, BLOCK A, "SOUTH AUDITORIUM ADDITION"  
SW1/4 SECTION 3, T.1S., R.1E., W.M.

CITY OF PORTLAND  
MULTNOMAH COUNTY, OREGON  
SURVEYED NOVEMBER 23, 2005  
SHEET 10 OF 11



**LEGEND**

- CGE DENOTES GENERAL COMMON ELEMENT
- LCE DENOTES LIMITED COMMON ELEMENT
- P NO. DENOTES PARKING UNIT NUMBER
- TR. DENOTES TYPICAL

NOTE: ALL UNITS ON A PARTICULAR FLOOR ARE AT THAT FLOOR'S ELEVATION UNLESS OTHERWISE NOTED



PARKING UNIT SECTION B-B  
NOT TO SCALE

BASES OF ELEVATIONS - CITY OF PORTLAND RECORD 8103, A 2'-1/2" REBAR BESS IN THE EAST END OF CONCRETE ISLAND ON THE APPROXIMATE CENTERLINE OF S.W. LINCOLN STREET NEAR THE INTERSECTION WITH S.W. 15TH AVENUE. ELEVATION = 121.302, CITY OF PORTLAND DATUM.

REGISTERED PROFESSIONAL LAND SURVEYOR  
OREGON  
JANUARY 10, 1988  
GARY PAUL ZIEGLER  
RENEWAL 12/31/2008  
I, Gary Paul Ziegler, Surveyor, do hereby certify that this is a true and correct copy of the original plat of HARRISON WEST CONDOMINIUMS.  
P.L.L.C. NO. 2098

|     |          |          |          |          |          |          |          |          |          |          |          |          |          |          |          |          |          |          |          |          |          |          |          |          |          |          |          |          |          |          |          |          |          |          |          |          |          |          |          |          |          |          |          |          |          |          |          |          |          |          |          |          |          |          |          |          |          |          |          |          |          |          |          |          |          |          |          |          |          |          |          |          |          |          |          |          |          |          |          |          |         |         |         |         |         |         |         |         |         |         |         |         |         |         |         |         |         |         |         |         |         |         |         |         |         |         |         |         |         |         |         |         |         |         |         |         |         |         |         |         |         |         |         |         |         |        |        |        |        |        |
|-----|----------|----------|----------|----------|----------|----------|----------|----------|----------|----------|----------|----------|----------|----------|----------|----------|----------|----------|----------|----------|----------|----------|----------|----------|----------|----------|----------|----------|----------|----------|----------|----------|----------|----------|----------|----------|----------|----------|----------|----------|----------|----------|----------|----------|----------|----------|----------|----------|----------|----------|----------|----------|----------|----------|----------|----------|----------|----------|----------|----------|----------|----------|----------|----------|----------|----------|----------|----------|----------|----------|----------|----------|----------|----------|----------|----------|----------|----------|----------|----------|---------|---------|---------|---------|---------|---------|---------|---------|---------|---------|---------|---------|---------|---------|---------|---------|---------|---------|---------|---------|---------|---------|---------|---------|---------|---------|---------|---------|---------|---------|---------|---------|---------|---------|---------|---------|---------|---------|---------|---------|---------|---------|---------|---------|---------|--------|--------|--------|--------|--------|
| LCE | UNIT 268 | UNIT 256 | UNIT 254 | UNIT 252 | UNIT 250 | UNIT 248 | UNIT 246 | UNIT 244 | UNIT 242 | UNIT 240 | UNIT 238 | UNIT 236 | UNIT 234 | UNIT 232 | UNIT 230 | UNIT 228 | UNIT 226 | UNIT 224 | UNIT 222 | UNIT 220 | UNIT 218 | UNIT 216 | UNIT 214 | UNIT 212 | UNIT 210 | UNIT 208 | UNIT 206 | UNIT 204 | UNIT 202 | UNIT 200 | UNIT 198 | UNIT 196 | UNIT 194 | UNIT 192 | UNIT 190 | UNIT 188 | UNIT 186 | UNIT 184 | UNIT 182 | UNIT 180 | UNIT 178 | UNIT 176 | UNIT 174 | UNIT 172 | UNIT 170 | UNIT 168 | UNIT 166 | UNIT 164 | UNIT 162 | UNIT 160 | UNIT 158 | UNIT 156 | UNIT 154 | UNIT 152 | UNIT 150 | UNIT 148 | UNIT 146 | UNIT 144 | UNIT 142 | UNIT 140 | UNIT 138 | UNIT 136 | UNIT 134 | UNIT 132 | UNIT 130 | UNIT 128 | UNIT 126 | UNIT 124 | UNIT 122 | UNIT 120 | UNIT 118 | UNIT 116 | UNIT 114 | UNIT 112 | UNIT 110 | UNIT 108 | UNIT 106 | UNIT 104 | UNIT 102 | UNIT 100 | UNIT 98 | UNIT 96 | UNIT 94 | UNIT 92 | UNIT 90 | UNIT 88 | UNIT 86 | UNIT 84 | UNIT 82 | UNIT 80 | UNIT 78 | UNIT 76 | UNIT 74 | UNIT 72 | UNIT 70 | UNIT 68 | UNIT 66 | UNIT 64 | UNIT 62 | UNIT 60 | UNIT 58 | UNIT 56 | UNIT 54 | UNIT 52 | UNIT 50 | UNIT 48 | UNIT 46 | UNIT 44 | UNIT 42 | UNIT 40 | UNIT 38 | UNIT 36 | UNIT 34 | UNIT 32 | UNIT 30 | UNIT 28 | UNIT 26 | UNIT 24 | UNIT 22 | UNIT 20 | UNIT 18 | UNIT 16 | UNIT 14 | UNIT 12 | UNIT 10 | UNIT 8 | UNIT 6 | UNIT 4 | UNIT 2 | UNIT 1 |
| LCE | UNIT 268 | UNIT 256 | UNIT 254 | UNIT 252 | UNIT 250 | UNIT 248 | UNIT 246 | UNIT 244 | UNIT 242 | UNIT 240 | UNIT 238 | UNIT 236 | UNIT 234 | UNIT 232 | UNIT 230 | UNIT 228 | UNIT 226 | UNIT 224 | UNIT 222 | UNIT 220 | UNIT 218 | UNIT 216 | UNIT 214 | UNIT 212 | UNIT 210 | UNIT 208 | UNIT 206 | UNIT 204 | UNIT 202 | UNIT 200 | UNIT 198 | UNIT 196 | UNIT 194 | UNIT 192 | UNIT 190 | UNIT 188 | UNIT 186 | UNIT 184 | UNIT 182 | UNIT 180 | UNIT 178 | UNIT 176 | UNIT 174 | UNIT 172 | UNIT 170 | UNIT 168 | UNIT 166 | UNIT 164 | UNIT 162 | UNIT 160 | UNIT 158 | UNIT 156 | UNIT 154 | UNIT 152 | UNIT 150 | UNIT 148 | UNIT 146 | UNIT 144 | UNIT 142 | UNIT 140 | UNIT 138 | UNIT 136 | UNIT 134 | UNIT 132 | UNIT 130 | UNIT 128 | UNIT 126 | UNIT 124 | UNIT 122 | UNIT 120 | UNIT 118 | UNIT 116 | UNIT 114 | UNIT 112 | UNIT 110 | UNIT 108 | UNIT 106 | UNIT 104 | UNIT 102 | UNIT 100 | UNIT 98 | UNIT 96 | UNIT 94 | UNIT 92 | UNIT 90 | UNIT 88 | UNIT 86 | UNIT 84 | UNIT 82 | UNIT 80 | UNIT 78 | UNIT 76 | UNIT 74 | UNIT 72 | UNIT 70 | UNIT 68 | UNIT 66 | UNIT 64 | UNIT 62 | UNIT 60 | UNIT 58 | UNIT 56 | UNIT 54 | UNIT 52 | UNIT 50 | UNIT 48 | UNIT 46 | UNIT 44 | UNIT 42 | UNIT 40 | UNIT 38 | UNIT 36 | UNIT 34 | UNIT 32 | UNIT 30 | UNIT 28 | UNIT 26 | UNIT 24 | UNIT 22 | UNIT 20 | UNIT 18 | UNIT 16 | UNIT 14 | UNIT 12 | UNIT 10 | UNIT 8 | UNIT 6 | UNIT 4 | UNIT 2 | UNIT 1 |
| LCE | UNIT 268 | UNIT 256 | UNIT 254 | UNIT 252 | UNIT 250 | UNIT 248 | UNIT 246 | UNIT 244 | UNIT 242 | UNIT 240 | UNIT 238 | UNIT 236 | UNIT 234 | UNIT 232 | UNIT 230 | UNIT 228 | UNIT 226 | UNIT 224 | UNIT 222 | UNIT 220 | UNIT 218 | UNIT 216 | UNIT 214 | UNIT 212 | UNIT 210 | UNIT 208 | UNIT 206 | UNIT 204 | UNIT 202 | UNIT 200 | UNIT 198 | UNIT 196 | UNIT 194 | UNIT 192 | UNIT 190 | UNIT 188 | UNIT 186 | UNIT 184 | UNIT 182 | UNIT 180 | UNIT 178 | UNIT 176 | UNIT 174 | UNIT 172 | UNIT 170 | UNIT 168 | UNIT 166 | UNIT 164 | UNIT 162 | UNIT 160 | UNIT 158 | UNIT 156 | UNIT 154 | UNIT 152 | UNIT 150 | UNIT 148 | UNIT 146 | UNIT 144 | UNIT 142 | UNIT 140 | UNIT 138 | UNIT 136 | UNIT 134 | UNIT 132 | UNIT 130 | UNIT 128 | UNIT 126 | UNIT 124 | UNIT 122 | UNIT 120 | UNIT 118 | UNIT 116 | UNIT 114 | UNIT 112 | UNIT 110 | UNIT 108 | UNIT 106 | UNIT 104 | UNIT 102 | UNIT 100 | UNIT 98 | UNIT 96 | UNIT 94 | UNIT 92 | UNIT 90 | UNIT 88 | UNIT 86 | UNIT 84 | UNIT 82 | UNIT 80 | UNIT 78 | UNIT 76 | UNIT 74 | UNIT 72 | UNIT 70 | UNIT 68 | UNIT 66 | UNIT 64 | UNIT 62 | UNIT 60 | UNIT 58 | UNIT 56 | UNIT 54 | UNIT 52 | UNIT 50 | UNIT 48 | UNIT 46 | UNIT 44 | UNIT 42 | UNIT 40 | UNIT 38 | UNIT 36 | UNIT 34 | UNIT 32 | UNIT 30 | UNIT 28 | UNIT 26 | UNIT 24 | UNIT 22 | UNIT 20 | UNIT 18 | UNIT 16 | UNIT 14 | UNIT 12 | UNIT 10 | UNIT 8 | UNIT 6 | UNIT 4 | UNIT 2 | UNIT 1 |



BUILDING SECTION A-A  
NOT TO SCALE

**HARRISON WEST CONDOMINIUMS**  
 A PORTION OF LOT 2, BLOCK A, "SOUTH AUDITORIUM ADDITION"  
 SW1/4 SECTION 3, T.1S., R.1E., W.M.  
 CITY OF PORTLAND  
 MULTNOMAH COUNTY, OREGON  
 SURVEYED NOVEMBER 23, 2005  
 SHEET 11 OF 11

BOOK 1214 PAGE 109

**DECLARATION**

KNOWN ALL PERSONS BY THESE PRESENTS, THAT PORTLAND CENTER INVESTORS, LLC, A DELAWARE LIMITED LIABILITY COMPANY, DOES HEREBY MAKE, ESTABLISH AND DECLARE THE ANNOUNCED MAP OF "HARRISON WEST CONDOMINIUMS", AS DESCRIBED IN THE ACCOMPANYING SURVEYOR'S CERTIFICATE TO BE A TRUE AND CORRECT MAP OF THE LANDS OWNED BY SAID DEVELOPMENT-PORTLAND CENTER, LLC, CO-MANAGER OF SAIT-WOOD DEVELOPMENT, LLC, THE OREGON CONDOMINIUM ACT AS Laid OUT IN CHAPTER 100 OF THE OREGON REVISED STATUTES, THE PROPERTY AND IMPROVEMENTS DESCRIBED AND DEPICTED ON THIS PLAT ARE SUBJECT TO THE PROVISIONS OF ORS 100.005 TO 100.025.

PORTLAND CENTER INVESTORS, LLC  
 A DELAWARE LIMITED LIABILITY COMPANY  
 BY: PORTLAND CENTER MEZZANINE LLC,  
 MANAGER  
 BY: PORTLAND CENTER HOLDING COMPANY LLC,  
 MANAGER  
 BY: SAI-WOOD DEVELOPMENT, LLC,  
 MANAGER  
 BY: SAIT DEVELOPMENT-PORTLAND CENTER, LLC,  
 CO-MANAGER  
 BY: RELIANCE DEVELOPMENT, INC.,  
 MEMBER  
 BY: \_\_\_\_\_  
 SCOTT D. STEHMAN  
 AUTHORIZED SIGNER

**ACKNOWLEDGMENT**

STATE OF OREGON }  
 COUNTY OF Clackamas }  
 THIS INSTRUMENT WAS ACKNOWLEDGED BEFORE ME ON April 26<sup>th</sup>, 2006,  
 BY SCOTT D. STEHMAN AS AUTHORIZED SIGNER OF RELIANCE DEVELOPMENT, INC., MEMBER OF  
 SAIT DEVELOPMENT-PORTLAND CENTER, LLC, CO-MANAGER OF SAIT-WOOD DEVELOPMENT, LLC,  
 MEMBER OF PORTLAND CENTER HOLDING COMPANY LLC, MANAGER OF PORTLAND CENTER  
 MEZZANINE LLC, MANAGER OF PORTLAND CENTER INVESTORS LLC, A DELAWARE LIMITED LIABILITY  
 COMPANY.

*April S. Engel*  
 Notary Public - Oregon  
 COMMISSION NUMBER 391603  
 MY COMMISSION EXPIRES April 10, 2009

**APPROVALS**

APPROVED THIS 1<sup>st</sup> DAY OF May, 2006  
 COUNTY SURVEYOR, MULTNOMAH COUNTY, OREGON  
 BY: *[Signature]*  
 ALL TAXES, FEES, ASSESSMENTS OR OTHER CHARGES AS PROVIDED  
 BY O.A.S. 100.110 HAVE BEEN PAID AS OF May 3, 2006  
 DIRECTOR  
 DIVISION OF ASSESSMENT AND TAXATION, MULTNOMAH COUNTY, OREGON  
 BY: *[Signature]*

**NOTES AND RESTRICTIONS**

- SEE NARRATIVE FOR BASIS OF BEARINGS AND BOUNDARY DETERMINATION.
- BALCONIES ARE LIMITED COMMON ELEMENTS TO THE ADJOINING UNIT.
- SUBJECT TO THE DECLARATION SUBMITTING "HARRISON WEST CONDOMINIUMS" TO THE MULTNOMAH COUNTY RECORDS IN DOCUMENT NO. 2006-080487.
- BASIS OF ELEVATIONS: CITY OF PORTLAND BENCH JUDICIAL A 2-117' BRASS MARKER AT INTERSECTION OF S.W. LINCOLN STREET NEAR THE INTERSECTION WITH S.W. 1ST AVENUE. ELEVATION = 121.302', CITY OF PORTLAND DATUM.

REGISTERED  
 PROFESSIONAL  
 LAND SURVEYOR  
*[Signature]*  
 OREGON  
 JANUARY 6, 1994  
 GARY PAUL  
 12/31/2006  
 THIS IS AN E-COPY OF  
 THE ORIGINAL PLAT  
 WEST CONDOMINIUMS.  
*[Signature]*  
 P.L.L. NO. 2005

STATE OF OREGON }  
 COUNTY OF MULTNOMAH }  
 I DO HEREBY CERTIFY THAT THE ATTACHED CONDOMINIUM PLAT WAS RECEIVED FOR  
 RECORD AND INDEXED IN BOOK 1214, ON PAGE 109, AT 12:26 O'CLOCK P.M.  
 MULTNOMAH COUNTY RECORDING OFFICE  
 BY: *[Signature]*  
 DOCUMENT NO. 2006-080487

39

**After Recording, Return to:**  
Stoel Rives LLP  
900 SW Fifth Ave., Suite 2600  
Portland, Oregon 97204  
Attn: Howard Feuerstein

Recorded in MULTNOMAH COUNTY, OREGON  
C. Swick, Deputy Clerk  
C73 39 ATKRH  
Total : 216.00

2006-070734 04/18/2006 03:51:36pm

**MASTER DECLARATION OF COVENANTS, CONDITIONS, RESTRICTIONS  
AND EASEMENTS FOR HARRISON CENTER**

**PORTLAND CENTER INVESTORS, LLC  
Declarant**

39

**TABLE OF CONTENTS**

|           |  | <b>Page</b> |
|-----------|--|-------------|
| ARTICLE 1 | DEFINITIONS .....                          | 1           |
| 1.1       | “Articles” .....                           | 1           |
| 1.2       | “Assessments” .....                        | 1           |
| 1.3       | “Association” .....                        | 2           |
| 1.4       | “Association Expenses” .....               | 2           |
| 1.5       | “Board” .....                              | 2           |
| 1.6       | “Bylaws” .....                             | 2           |
| 1.7       | “Community Facilities” .....               | 2           |
| 1.8       | “Condominium Owners Association” .....     | 2           |
| 1.9       | “Declarant” .....                          | 2           |
| 1.10      | “Emergency Assessments” .....              | 2           |
| 1.11      | “General Assessments” .....                | 2           |
| 1.12      | “Governing Documents” .....                | 2           |
| 1.13      | “Governmental Authority” .....             | 2           |
| 1.14      | “Harrison Center” .....                    | 2           |
| 1.15      | “Individual Assessments” .....             | 2           |
| 1.16      | “Mortgage” .....                           | 2           |
| 1.17      | “Mortgagee” .....                          | 2           |
| 1.18      | “Owner” .....                              | 2           |
| 1.19      | “Person” .....                             | 3           |
| 1.20      | “Property” .....                           | 3           |
| 1.21      | “Recorded” .....                           | 3           |
| 1.22      | “Rules and Regulations” .....              | 3           |
| 1.23      | “Special Assessments” .....                | 3           |
| 1.24      | “This Declaration” .....                   | 3           |
| 1.25      | “Turnover Meeting” .....                   | 3           |
| 1.26      | “Unit” .....                               | 3           |
| ARTICLE 2 | PROPERTY SUBJECT TO THIS DECLARATION ..... | 3           |
| ARTICLE 3 | DESIGNATION OF COMMUNITY FACILITIES .....  | 3           |
| 3.1       | Community Facilities .....                 | 3           |
| 3.2       | Future Community Facilities .....          | 3           |
| ARTICLE 4 | USE OF COMMUNITY FACILITIES .....          | 4           |
| 4.1       | Use by Owners .....                        | 4           |
| 4.2       | Restrictions on Use .....                  | 4           |
| (a)       | Offensive or Unlawful Activities .....     | 4           |

|           |     |  |   |
|-----------|-----|--|---|
|           | (b) | Rules and Regulations.....   | 4 |
|           | (c) | Governing Documents .....  | 4 |
| 4.3       |     | Easements Reserved.....  | 4 |
|           | (a) | In Favor of Association.....   | 4 |
|           | (b) | Reserved by Declarant .....  | 4 |
|           | (c) | In Favor of Governmental Authorities and Utilities. ....             | 4 |
| ARTICLE 5 |     | MAINTENANCE COVENANTS AND ARCHITECTURAL REVIEW .....                 | 5 |
| 5.1       |     | Maintenance Covenant. ....   | 5 |
| 5.2       |     | Architectural Review of Improvements. ....                           | 5 |
| ARTICLE 6 |     | HARRISON CENTER MASTER ASSOCIATION.....                              | 5 |
| 6.1       |     | Organization.....  | 5 |
| 6.2       |     | Membership.....  | 5 |
| 6.3       |     | Voting Rights .....  | 5 |
| 6.4       |     | General Powers and Obligations. ....                                 | 6 |
| 6.5       |     | Specific Powers and Duties.....                                      | 6 |
|           | (a) | Management and Maintenance of Community Facilities. ....             | 6 |
|           | (b) | Review of Proposed Exterior and Landscaping Improvements. ....       | 6 |
|           | (c) | Fixtures and Equipment. ....   | 6 |
|           | (d) | Taxes and Charges. ....  | 6 |
|           | (e) | Utility Services.....  | 6 |
|           | (f) | Rules and Regulations.....   | 6 |
|           | (g) | Legal and Accounting Services.....                                   | 7 |
|           | (h) | Insurance .....  | 7 |
|           | (i) | Other Acts .....   | 7 |
|           | (j) | Assessments. ....  | 7 |
|           | (k) | Enforcement .....  | 7 |
|           | (l) | Managing Agent.....  | 7 |
|           | (m) | Administration of Particular Areas within Harrison Center.....       | 7 |
|           | (n) | Assumption of Other's Maintenance Responsibility.....                | 7 |
|           | (o) | Implied Rights and Obligations. ....                                 | 7 |
| 6.6       |     | Liability. ....  | 7 |
| 6.7       |     | Interim Board; Turnover Meeting. ....                                | 8 |
| 6.8       |     | Contracts Entered into by Declarant or Before Turnover Meeting ..... | 8 |
| 6.9       |     | Bylaws.....  | 8 |
| ARTICLE 7 |     | ASSESSMENTS .....  | 8 |

|            |  |    |
|------------|--|----|
| 7.1        | Power to Assess.....                                   | 8  |
| 7.2        | General Assessments.....                               | 8  |
|            | (a) Budget.....  | 8  |
|            | (b) Allocation.....                                    | 9  |
|            | (c) Payment.....                                       | 9  |
| 7.3        | Special Assessments.....                               | 9  |
| 7.4        | Emergency Assessments.....                             | 9  |
| 7.5        | Individual Assessments.....                            | 9  |
| 7.6        | Operations Fund.....                                   | 9  |
| 7.7        | Reserve Fund.....                                      | 10 |
|            | (a) Establishment of Account.....                      | 10 |
|            | (b) Funding of Reserve Fund.....                       | 10 |
|            | (c) Reserve Studies.....                               | 10 |
|            | (d) Use of Reserve Fund.....                           | 10 |
| 7.8        | No Waiver.....   | 11 |
| ARTICLE 8  | ENFORCEMENT.....                                       | 11 |
| 8.1        | Violation of Declaration or Rules and Regulations..... | 11 |
| 8.2        | Interest, Expenses and Attorneys' Fees.....            | 11 |
| 8.3        | Responsibility of Owners.....                          | 12 |
| 8.4        | Nonexclusiveness and Accumulation of Remedies.....     | 12 |
| 8.5        | Dispute Resolution.....                                | 12 |
|            | (a) Mediation.....                                     | 12 |
|            | (b) Costs and Attorneys' Fees.....                     | 12 |
|            | (c) Survival.....                                      | 13 |
| ARTICLE 9  | AMENDMENT AND REPEAL.....                              | 13 |
| 9.1        | How Proposed.....                                      | 13 |
| 9.2        | Approval Required.....                                 | 13 |
| 9.3        | Recordation.....                                       | 13 |
| 9.4        | Regulatory Amendments.....                             | 13 |
| ARTICLE 10 | MISCELLANEOUS PROVISIONS.....                          | 14 |
| 10.1       | No Implied Obligations.....                            | 14 |
| 10.2       | Right to Transfer or Assign Declarant's Rights.....    | 14 |
| 10.3       | Duration.....  | 14 |
| 10.4       | Joint Owners.....                                      | 14 |
| 10.5       | Lessees and Other Invitees.....                        | 14 |
| 10.6       | Nonwaiver.....   | 14 |

10.7 Construction; Severability; Number; Captions. ....14  
10.8 Terminology and Captions. ....14  
10.9 Notices and Other Documents.....15



**MASTER DECLARATION OF COVENANTS, CONDITIONS, RESTRICTIONS  
AND EASEMENTS FOR HARRISON CENTER**

**THIS DECLARATION** is made this 20<sup>th</sup> day of March, 2006 by **PORTLAND CENTER INVESTORS, LLC**, an Oregon limited liability company ("**Declarant**").

**RECITALS:**

A. Declarant owns certain real property and improvements in Multnomah County, Oregon known as the Portland Center Apartments. The Portland Center Apartments is comprised of three apartment buildings with attached townhouses (each an "**Apartment Project**"). Declarant intends to convert the Apartment Projects into three condominiums to be known as "Harrison West Condominiums," "Harrison East Condominiums" and "Harrison South Condominiums" (each a "**Condominium Project**"). Collectively, the Apartment Projects which will be converted to the Condominium Projects shall be referred to herein as "**Harrison Center**." The real property which will be subject to such declaration is described in the attached Exhibit A. Harrison Center will be a Class I planned community under the Oregon Planned Community Act, ORS 94.550 to 94.783.

B. All property within Harrison Center will be subject to this Declaration which establishes and provides for the maintenance and operation of those recreational amenities which provide a community-wide benefit to all Owners within Harrison Center (the "**Community Facilities**").

C. By this Declaration, Declarant desires to provide for the use, maintenance and operation of the Community Facilities; to provide for the obligation of all Owners of property within Harrison Center to contribute to such costs; to set forth the method for allocating such costs among such Owners; and to provide for all necessary and appropriate easements for the use, maintenance and operation of the Community Facilities. In addition, Declarant desires to grant the Association the power to regulate the exterior appearance of the structures and landscaping within Harrison Center.

D. Declarant has established or intends to establish the Harrison Center Master Association as an Oregon nonprofit corporation to maintain and operate the Community Facilities and to administer the terms and conditions of this Declaration.

**NOW, THEREFORE**, Declarant hereby declares that the real property described in the attached Exhibit A shall be held, sold and conveyed subject to the following easements and covenants, which shall run with such property and shall be binding upon all parties having or acquiring any right, title or interest in such property and shall inure to the benefit of each owner thereof.

**ARTICLE 1**

**DEFINITIONS**

As used in this Declaration, the terms set forth below shall have the following meanings:

1.1 "**Articles**" means the Articles of Incorporation of the Association.

1.2 "**Assessments**" means all assessments and other charges, fines and fees imposed by the Association in accordance with this Declaration, including, without limitation, General Assessments, Special Assessments, Emergency Assessments and Individual Assessments as described in Article 7.

1.3 “**Association**” means the Harrison Center Master Association, an Oregon nonprofit corporation to be formed to administer this Declaration as provided in Article 6, and its successors and assigns.

1.4 “**Association Expenses**” shall mean all of the expenses incurred by or on behalf of the Association from time to time, including such reserves as the Board may deem appropriate from time to time.

1.5 “**Board**” means the Board of Directors of the Association.

1.6 “**Bylaws**” means the bylaws of the Association as adopted and amended from time to time.

1.7 “**Community Facilities**” means all real and personal property including easements and leaseholds designated as such in this Declaration for which the Association has maintenance, insurance, operating, or other responsibility under this Declaration or other agreements entered into by the Association.

1.8 “**Condominium Owners Association**” means the Harrison West Condominium Owners Association, Harrison East Condominium Owners Association, or the Harrison North Condominium Owners Association. Used in the plural, this term means all of the Condominium Owners Associations within Harrison Center.

1.9 “**Declarant**” means Portland Center Investors, LLC, an Oregon limited liability company, and its successors and assigns if a recorded instrument executed by Declarant assigns to the transferee all of the rights of Declarant under this Declaration with respect to all or any portion of Harrison Center.

1.10 “**Emergency Assessments**” shall have the meaning given that term in Section 7.4.

1.11 “**General Assessments**” shall have the meaning given that term in Section 7.2.

1.12 “**Governing Documents**” means this Declaration, the Articles, the Bylaws, and any Rules and Regulations adopted pursuant to this Declaration, as well as the Declaration, the Articles, the Bylaws pertaining to each Condominium Owners Association.

1.13 “**Governmental Authority**” means the County of Multnomah, the State of Oregon, the United States of America or other governmental entity or agency that has or acquires jurisdiction over the Property or any portion thereof, or sales of the Property, from time to time.

1.14 “**Harrison Center**” means the real property identified in Article 2, and all existing and future improvements located thereon

1.15 “**Individual Assessments**” shall have the meaning given that term in Section 7.5.

1.16 “**Mortgage**” means a mortgage, deed of trust or real estate installment sale contract.

1.17 “**Mortgagee**” means a mortgagee under a mortgage, a beneficiary under a deed of trust, or a seller under a real estate installment sale contract.

1.18 “**Owner**” means the Person, including Declarant, owning any Unit in the Property, but does not include a tenant or holder of a leasehold interest or a mortgagee or other Person holding only a security interest in a Unit. If a Unit is sold under a recorded real estate installment sale contract, the

purchaser (rather than the seller) will be considered the Owner unless the contract specifically provides to the contrary. If a Unit is subject to a written lease with a term in excess of one year and the lease specifically so provides, then upon filing a copy of the lease with the Association, the lessee (rather than the fee owner) will be considered the Owner during the term of the lease for the purpose of exercising any rights related to such Unit under this Declaration. The rights, obligations and other status of being an Owner commence upon acquisition of the ownership of a Unit and terminate upon disposition of such ownership, but termination of ownership shall not discharge an Owner from its obligations incurred prior to termination.

1.19 “**Person**” means a human being, a corporation, partnership, limited liability company, trustee or other legal entity.

1.20 “**Property**” means all of the land within Harrison Center, including all subsequent additions thereto and excluding any property withdrawn from the provisions of this Declaration.

1.21 “**Recorded**” means filed in the official records of Multnomah County, Oregon.

1.22 “**Rules and Regulations**” means those policies, procedures, rules and regulations adopted by the Association pursuant to the authority granted in this Declaration, as the same may be amended from time to time

1.23 “**Special Assessments**” shall have the meaning given that term in Section 7.3.

1.24 “**This Declaration**” means all of the easements, covenants, restrictions and charges set forth in this Declaration, together with any Rules and Regulations promulgated hereunder, as the same may be amended or supplemented from time to time in accordance with the provisions hereof.

1.25 “**Turnover Meeting**” means the meeting called by Declarant pursuant to Section 6.7 below, at which Declarant will turn over administration responsibility for the Community Facilities to the Association.

1.26 “**Unit**” means a residential condominium or apartment unit in any of the Apartment Projects or Condominium Projects within Harrison Center.

## ARTICLE 2

### PROPERTY SUBJECT TO THIS DECLARATION

Declarant hereby declares that all of the real property described in Exhibit A attached hereto is owned and shall be owned, conveyed, hypothecated, encumbered, leased, used, occupied and improved subject to this Declaration.

## ARTICLE 3

### DESIGNATION OF COMMUNITY FACILITIES

3.1 **Community Facilities.** The Community Facilities shall be the swimming pool and spa facility located within the Harrison South project.

3.2 **Future Community Facilities.** The Association may assume responsibility for additional Community Facilities upon the recording of an amendment to the Declaration declaring the same.

## ARTICLE 4

### USE OF COMMUNITY FACILITIES

4.1 **Use by Owners.** Subject to the provisions of this Declaration and the Rules and Regulations adopted hereunder, each Owner shall have a right and easement in and over the Community Facilities for the uses for which they are established, which easement shall be appurtenant to and pass with the title to such Owner's Unit. Any Owner may extend the Owner's right of use and enjoyment of the Community Facilities to the members of the Owner's immediate family, social or business invitees, agents, employees and lessees as applicable, subject to reasonable regulation by the Association. An Owner who leases the Owner's property shall be deemed to have assigned all such rights to the lessee of such property for the period of the lease.

4.2 **Restrictions on Use.** The following restrictions shall apply to the Community Facilities as provided below:

(a) **Offensive or Unlawful Activities.** No noxious or offensive activities shall be carried on within the Community Facilities, nor shall anything be done or placed on the Community Facilities which interferes with or jeopardizes the enjoyment of the Community Facilities, or which is a source of annoyance to Owners or occupants. No unlawful use shall be made of the Community Facilities nor any part thereof, and all laws and regulations of all Governmental Authorities shall be observed.

(b) **Rules and Regulations.** In addition to the restrictions in this Declaration, the Association from time to time may adopt, modify or revoke such Rules and Regulations governing the conduct of Persons and the operation and use of the Community Facilities as it may deem necessary or appropriate in order to assure the peaceful and orderly use and enjoyment of the Community Facilities. A copy of the Rules and Regulations, upon adoption, and a copy of each amendment, modification or revocation thereof, shall be furnished by the Association to each Owner directly or to a Condominium Owners Association for delivery to its members and shall be binding upon all Owners and occupants of property within Harrison Center.

(c) **Governing Documents.** Use of the Community Facilities shall be subject to any additional restrictions contained in any of the applicable Governing Documents.

4.3 **Easements Reserved.**

(a) **In Favor of Association.** There are hereby reserved and granted to the Association its contractors and employees, perpetual, nonexclusive blanket easements over, under and across the Community Facilities and such portions of the Property as are necessary for access, ingress and egress to and from the Community Facilities and to enable the Association to fulfill its responsibilities under this Declaration; provided, the exercise of such easements shall not unreasonably interfere with the use and enjoyment of the burdened Property and, upon completion of work, the Association shall restore such Property to the condition existing immediately prior to the exercise of such easement, to the extent reasonably possible.

(b) **Reserved by Declarant.** So long as Declarant owns any real property within Harrison Center, Declarant reserves an easement over, under and across the Community Facilities in order to carry out management, sales and rental activities necessary or convenient for the sale or rental of Units. This easement includes, but is not limited to, a right of ingress and egress over the Community Facilities.

(c) **In Favor of Governmental Authorities and Utilities.** The Community Facilities shall be subject to any easements reserved or granted by Declarant or the Association to

Governmental Authorities or companies providing utility and communication services and to police, fire and other public officials.

## ARTICLE 5

### MAINTENANCE COVENANTS AND ARCHITECTURAL REVIEW

5.1 **Maintenance Covenant.** The owner of each Apartment Project shall maintain in an attractive and safe condition the exterior of the buildings, all common areas and the landscaping within each such owner's portion of Harrison Center. Upon the creation of the Condominium Projects, each Condominium Project's Governing Documents will provide that its Condominium Owners Association will assume the maintenance and repair obligations for these elements located within each such Condominium Project.

5.2 **Architectural Review of Improvements.** The Association shall have the authority to review and approve any proposed improvements or alterations to the exterior of the buildings and the landscaping plan within Harrison Center for compatibility with the overall appearance of Harrison Center. Prior to constructing or altering any exterior improvements, which shall include exterior painting, or significantly altering a landscaping plan, the owner of the particular apartment project or, if applicable, the Condominium Owners Association, shall submit a proposal of such alterations to the Board for review and approval. The Board shall have thirty (30) days from the date it receives the proposal to approve or deny the proposal or to request additional information relating thereto. Failure by the Association to respond within such time period shall be deemed an approval of the proposal.

## ARTICLE 6

### HARRISON CENTER MASTER ASSOCIATION

Declarant shall organize the Association as the association of all of the Owners within Harrison Center. Such Association, and its successors and assigns, shall have such powers and obligations as are set forth in this Declaration for the benefit of Harrison Center and all Owners of property located therein.

6.1 **Organization.** Declarant shall, before the first Unit is conveyed to an Owner, organize the Association as a nonprofit corporation under the general nonprofit corporation laws of the State of Oregon. The Articles of Incorporation of the Association shall provide for its perpetual existence, but in the event the Association is at any time dissolved, whether inadvertently or deliberately, it shall automatically be succeeded by an unincorporated association of the same name. In that event all of the powers and obligations of the incorporated Association existing immediately prior to its dissolution shall thereupon automatically vest in the successor unincorporated Association, and such vesting shall thereafter be confirmed as evidenced by appropriate conveyances and assignments by the incorporated Association. To the greatest extent possible, any successor unincorporated Association shall be governed by the Articles of Incorporation and Bylaws of the Association as if they had been made to constitute the governing documents of the unincorporated Association.

6.2 **Membership.** Every Owner of one or more Units within Harrison Center shall, immediately upon creation of the Association and thereafter during the entire period of such Owner's ownership of one or more Units within Harrison Center, be a member of the Association. Such membership shall commence, exist and continue simply by virtue of such ownership, shall expire automatically upon termination of such ownership, and need not be confirmed or evidenced by any certificate or acceptance of membership.

6.3 **Voting Rights.** Voting rights within the Association shall be allocated and cast as follows: voting rights in the affairs of the Association shall be cast by voting representatives. Each

Apartment or Condominium Project shall be allocated one vote for a total of three votes. The owner of each Apartment Project will cast the Apartment Project's vote. Upon the conversion of each Apartment Project to a Condominium Project, the board of directors of the corresponding Condominium Owners Association will act as the Condominium Project's voting representative. Owners of Units will be represented by their voting representative and will not individually have a vote in the affairs of the Association.

6.4 **General Powers and Obligations.** The Association shall have, exercise and perform all of the following powers, duties and obligations:

(a) The powers, duties and obligations granted to the Association by this Declaration.

(b) The powers and obligations of a nonprofit corporation pursuant to the general nonprofit corporation laws of the State of Oregon.

(c) The powers, duties and obligations of a homeowners' association pursuant to the Oregon Planned Community Act.

(d) Any additional or different powers, duties and obligations necessary or desirable for the purpose of carrying out the functions of the Association pursuant to this Declaration or otherwise promoting the general benefit of the Owners within the Property.

The powers and obligations of the Association may from time to time be amended, repealed, enlarged or restricted by changes in this Declaration made in accordance with the provisions herein, accompanied by changes in the Articles of Incorporation or Bylaws made in accordance with such instruments and with the nonprofit corporation laws of the State of Oregon.

6.5 **Specific Powers and Duties.** The powers and duties of the Association shall, to be exercised by the Board, include, without limitation, the following:

(a) **Management and Maintenance of Community Facilities.** Manage, operate, repair and maintain the Community Facilities.

(b) **Review of Proposed Exterior and Landscaping Improvements.** Review and regulate all proposed changes in the color and appearance of the exterior of the structures and the landscaping within Harrison Center for the purpose of maintaining a uniform and attractive appearance of such elements.

(c) **Fixtures and Equipment.** Acquire or lease, repair and replace fixtures and equipment for the Community Facilities.

(d) **Taxes and Charges.** Pay all taxes, assessments, maintenance contracts and other costs and charges affecting or related to the Community Facilities and discharge, contest or protest liens or charges affecting the Community Facilities.

(e) **Utility Services.** Obtain and pay the cost of electrical and other utility services the Board deems appropriate for the Community Facilities.

(f) **Rules and Regulations.** Adopt from time to time and enforce Rules and Regulations relating to use and enjoyment of the Community Facilities by the Owners and their family members, social or business invitees, agents, employees and lessees, and by the public.

(g) **Legal and Accounting Services.** Obtain and pay for the cost of legal and accounting services necessary or appropriate for the maintenance and operation of the Community Facilities and the enforcement of this Declaration.

(h) **Insurance.** Obtain and pay for the cost of insurance insuring against liability for personal injury or property damage resulting from an occurrence in, on or about the Community Facilities and such other insurance as the Board deems appropriate.

(i) **Other Acts.** Do all other acts or things necessary or appropriate to the ordinary and necessary operation and maintenance of the Community Facilities and to preserve and protect the same in the event of any emergency.

(j) **Assessments.** Adopt budgets and impose and collect Assessments.

(k) **Enforcement.** Enforce the terms of this Declaration.

(l) **Managing Agent.** Contract with a managing agent for the performance of any or all of the obligations herein.

(m) **Administration of Particular Areas within Harrison Center.** In addition to its other powers and obligations, the Association may be obligated by Declarant or agreement to provide maintenance, architectural review, Assessment collection, rules enforcement or such other services to, and levy Assessments against, Owners within particular areas of Harrison Center. In such event, the Association shall provide such services in the manner prescribed, and the expenses of such services shall be allocated and assessed as provided in the covenants, easements, or agreement obligating the Association. In the event of a conflict between such other covenants, easements, or agreements and this Declaration, this Declaration shall control.

(n) **Assumption of Other's Maintenance Responsibility.** The Association may, but shall not be obligated to, assume maintenance responsibility for property which is the responsibility of another Person (e.g., a Condominium Owners Association or any local or state Governmental Authority) if, in the discretion of the Board, the maintenance of such property provides a benefit to the Harrison Center community and/or such property is not otherwise being properly maintained. The cost of maintenance assumed in accordance with this Section may be a Common Expense to be allocated among all Owners or may be Individual Assessments levied only against the benefited parties.

(o) **Implied Rights and Obligations.** The Association may exercise any other right or privilege reasonably to be implied from the existence of any right or privilege expressly given to the Association under this Declaration or reasonably necessary to effectuate any such right or privilege.

6.6 **Liability.** Neither a member of the Board nor an officer of the Association or a member of any committee established by the Association shall be liable to the Association, any Owner or any third party for any damage, loss or prejudice suffered or claimed on account of any action or failure to act in the performance of his duties, so long as the individual acted in good faith, believed that the conduct was in the best interests of the Association, or at least was not opposed to its best interests, and in the case of criminal proceedings, had no reason to believe the conduct was unlawful. In the event any member of the Board or any officer or committee member of the Association is threatened with or made a party to any proceeding because the individual was or is a director, officer or committee member of the Association, the Association shall defend such individual against such claims and indemnify such individual against liability and expenses incurred to the maximum extent permitted by law. The managing agent of the Association, and its officers and employees, shall not be liable to the Association, the Owners or any third party on account of any action or failure to act in the performance of its duties as managing agent, except for acts of gross negligence or intentional acts, and the Association shall indemnify the managing agent

and its officers and employees from any such claims, other than for gross negligence or intentional misconduct.

6.7 **Interim Board; Turnover Meeting.** Declarant shall have the right to appoint an interim Board of one to three directors, who shall serve as the Board of the Association until replaced by Declarant or until their successors take office at the Turnover Meeting. Declarant shall call a meeting of the Association for the purpose of turning over administrative responsibility for Harrison Center to the Association not later than ninety (90) days after the recordation of the first Condominium Project plat in Harrison Center. If Declarant fails to call the Turnover Meeting required by this Section, any Owner or Mortgagee of a Unit may call the meeting by giving notice as provided in the Bylaws. At the Turnover Meeting the interim directors shall resign and their successors shall be elected or appointed. The owner of each Apartment Project within Harrison Center shall each initially appoint one representative to serve on the Association's Board of Directors for a total of three directors. Each director appointed by the owner of an Apartment Project shall serve until it is replaced by the owner of the Apartment Project, or until the owner of the Apartment Project forms the corresponding Condominium Project and turns over control of the Condominium Owners Association to the Owners of Units in that Condominium Project. At the turnover meeting of each Condominium Project, the director appointed by the owner of the Apartment Project shall resign and the Board of Directors of the Condominium Owners Association shall elect a director to represent the Condominium Owners Association to serve on the Board of the Association.

6.8 **Contracts Entered into by Declarant or Before Turnover Meeting.** Notwithstanding any other provision of this Declaration, any management contracts, service contracts or employment contracts entered into by Declarant or the Board on behalf of the Association before the Turnover Meeting shall have a term of not more than three (3) years. In addition, any such contract shall provide that it may be terminated without cause or penalty by the Association or Board upon not less than thirty (30) days' notice to the other party given not later than sixty (60) days after the Turnover Meeting.

6.9 **Bylaws.** The Bylaws of the Association and any amendment or modification of the Bylaws shall be recorded in the Deed Records of Multnomah County, Oregon. Declarant hereby adopts, on behalf of the Association, the initial Bylaws attached as Exhibit B to this Declaration.

## ARTICLE 7

### ASSESSMENTS

7.1 **Power to Assess.** The Association may levy Assessments. The Assessments levied by the Association shall be used for the purpose of carrying out the powers and obligations of the Association as provided in Article 6 above. The obligation to pay assessments under this Declaration shall commence upon adoption of the initial budget by the Board and the levying of Assessments in accordance with this Article 7.

#### 7.2 **General Assessments.**

(a) **Budget.** At least 60 days prior to the beginning of each fiscal year, the Board shall prepare a budget of the estimated Association Expenses for the coming year, including any contributions to be made to a reserve fund pursuant to Section 7.7 below. The budget shall also reflect the sources and estimated amount of funds to cover such expenses, which may include any surplus to be applied from prior years, any income expected from sources other than Assessments, and the amount to be generated through the levy of General Assessments and Special Assessments as authorized in accordance with this Article 7.



(b) **Allocation.** General Assessments shall commence upon the recordation of this Declaration in the Official Records of Multnomah County, Oregon. The General Assessments shall be allocated among the three Apartment Projects in Harrison Center based on the relative number of residential Units in each building, as compared to the total number of residential Units in Harrison Center combined. Each building's portion of the General Assessments shall be billed by the Association to the owner of each Apartment Project. Upon the formation of each Condominium Owners Association, the Association shall then bill each Condominium Owners Association for its corresponding share of the General Assessments, and each Condominium Owners Association shall in turn assess its Owners a proportional share.

(c) **Payment.** General Assessments shall be paid in such manner and on such dates as the Association may establish. Each Condominium Owners Association shall include as a line item in its common expense budget and shall be responsible for collecting and paying to the Association the total amount of the Assessments levied by the Association against such association. Such amounts shall have first priority for payment out of the income of the Association. Until the Turnover Meeting, any obligation of Declarant to pay Assessments may be satisfied in the form of cash or by "in kind" contributions of services or materials, or by a combination of these.

7.3 **Special Assessments.** The Board may levy during any fiscal year a Special Assessment, applicable to that year only, for the purpose of deferring all or any part of the cost of any construction or reconstruction, unexpected repair, or acquisition or replacement of a described capital improvement or for any other one-time expenditure not to be paid for out of General Assessments. Special Assessments for acquisition or construction of new capital improvements or additions which in the aggregate in any fiscal year exceed an amount equal to fifteen percent (15%) of the budgeted gross expenses of the Association for the fiscal year may be levied only if approved by a majority of the voting rights voting on such matter, together with the written consent of Declarant prior to the Turnover Meeting. Special Assessments shall be apportioned as provided in Section 7.2(a) and may be payable in lump sum or in installments, with or without interest or discount, as determined by the Board.

7.4 **Emergency Assessments.** If the General Assessments levied at any time are or will become inadequate to meet all expenses incurred under this Declaration for any reason, the Board shall immediately determine the approximate amount of such inadequacy and issue a supplemental budget, noting the reason therefor, and levy an Emergency Assessment for the amount required to meet all such expenses on a current basis. Emergency Assessments shall be apportioned as set forth in Section 7.2(a) above and payable as determined by the Board.

7.5 **Individual Assessments.** Any Association Expense or any part of an Association Expense benefiting fewer than all of the Units, may be assessed exclusively against the corresponding Condominium Owners Association which governs the benefited Units as an Individual Assessment. Individual Assessments shall also include Assessments levied against any Unit or Owner to reimburse the Association for costs incurred in bringing such Unit or its Owner into compliance with the provisions of this Declaration or the Rules and Regulations of the Association and for fines or other charges imposed pursuant to this Declaration for violation thereof. Individual Assessments relating to violations of the Rules and Regulations or Declaration shall be assessed directly against the violating Unit or Owner. Unless otherwise provided by the Board, the Individual Assessments shall be due 30 days after the Association has given written notice thereof to the Owner or Condominium Owners Association(s) subject to the Individual Assessment.

7.6 **Operations Fund.** The Association shall keep all funds received by it as Assessments, other than reserves described in Section 7.7, separate and apart from its other funds, in an Operations Fund held in a bank account in the State of Oregon in the name of the Association.

7.7 **Reserve Fund.**

(a) **Establishment of Account.** Declarant shall conduct a reserve study as described in paragraph (c) of this Section and establish a Reserve Fund in a bank account in the State of Oregon in the name of the Association for replacement of the Community Facilities that will normally require replacement in whole or in part in more than three (3) and less than thirty (30) years, and for other items, whether or not involving Community Facilities, if the Association has responsibility to maintain the items. The Reserve Fund need not include those items that could reasonably be funded from operating Assessments or for those items for which one or more Owners are responsible for maintenance and replacement under the provisions of this Declaration or the Bylaws.

(b) **Funding of Reserve Fund.** The Reserve Fund shall be funded by Assessments against the individual Unit assessed for maintenance of the items for which the Reserve Fund is being established, which sums shall be included in the regular General Assessment for the Unit. The Reserve Fund shall be established in the name of the Association. The Association is responsible for administering the Reserve Fund and making periodic payments into it.

(c) **Reserve Studies.** The reserve portion of the initial Assessment determined by Declarant shall be based on a reserve study described in this paragraph (c) or other sources of information. The Board annually shall conduct a reserve study, or review and update an existing study, to determine the Reserve Fund requirements and may adjust the amount of payments as indicated by the study or update and provide other reserve items that the Board, in its discretion, may deem appropriate. The reserve study shall include:

- (i) Identification of all items for which reserves are to be established;
- (ii) The estimated remaining useful life of each item as of the date of the reserve study;
- (iii) The estimated cost of maintenance, repair or replacement of each item at the end of its useful life;
- (iv) A thirty (30) year plan with regular and adequate contributions, adjusted by estimated inflation and interest earned on reserves, to meet the maintenance, repair and replacement schedule.

(d) **Use of Reserve Fund.** The Reserve Fund shall be used only for the purposes for which the reserves have been established and shall be kept separate from other funds. After the Turnover Meeting, however, the Board may borrow funds from the Reserve Fund to meet high seasonal demands on the regular operating funds or to meet unexpected increases in expenses if the Board has adopted a resolution, which may be an annual continuing resolution, authorizing the borrowing of funds. Not later than the adoption of the budget for the following year, the Board shall adopt by resolution a written payment plan providing for repayment of the borrowed funds within a reasonable period. Nothing in this Section shall prohibit prudent investment of the Reserve Fund. In addition to the authority of the Board under paragraph (c) of this Section, following the second year after the Turnover Meeting, the Board may elect to reduce or increase future Assessments for the Reserve Fund by an affirmative vote of not less than seventy-five percent (75%) of the voting power of the Board and may, on an annual basis by a unanimous vote, elect not to fund the Reserve Fund. Assessments paid into the Reserve Fund are the property of the Association and are not refundable to sellers or Owners of Units. Sellers of the Units, however, may treat their outstanding share of the Reserve Fund as a separate item in any sales agreement.

7.8 **No Waiver.** Failure of the Board to fix Assessment amounts or rates or to deliver or mail each Condominium Owners Association an Assessment notice shall not be deemed a waiver, modification, or a release of any Condominium Owners Association from the obligation to pay Assessments. In such event, each Condominium Owners Association shall continue to pay Assessments on the same basis as during the last year for which an Assessment was made, if any, until a new Assessment is levied, at which time the Association may retroactively assess any shortfalls in collections.

## ARTICLE 8

### ENFORCEMENT

8.1 **Violation of Declaration or Rules and Regulations.** In the event any Person violates the restrictions contained in this Declaration or the Rules and Regulations adopted pursuant to this Declaration, then the Association acting through its Board shall notify such Person in writing of any such specific violations and require the Person to remedy or abate the same. If the Person is unable, unwilling or refuses to comply with the Association's specific directives for remedy or abatement, then the Association, acting through its Board, after notice and reasonable opportunity to be heard, shall have the right to do any or all of the following:

(a) Assess reasonable fines against such Person based upon a resolution adopted by the Board that is delivered to each Condominium Owners Association, mailed to the mailing address of each Unit or mailed to the mailing address designated by the Owner of each Unit in writing, which fines shall constitute Individual Assessments for purposes of this Declaration;

(b) Exclude such Person from use of the Community Facilities until the violation has been corrected and for any additional reasonable period of time determined by the Association. In no event shall the Association deprive any Owner of access to and from the Owner's Unit;

(c) In the event of construction of an improvement in violation of this Declaration, remove, alter, repair or change the item which is in violation of this Declaration in such a manner as to make it conform to this Declaration, in which case the Association may assess to such Person the entire cost of the work done; or

(d) Bring suit or action against such Person on behalf of the Association to enforce this Declaration and to recover the amount of any damages to the Community Facilities, fines or other charges imposed pursuant to this Declaration.

8.2 **Interest, Expenses and Attorneys' Fees.** Any amount not paid to the Association when due in accordance with this Declaration shall bear interest from the due date until paid at 12% per annum, or such other rate as may be established by the Board, but not to exceed the lawful rate of interest under the laws of the State of Oregon. A late charge may be charged for each delinquent Assessment in an amount established from time to time by resolution of the Board, which resolution is delivered to each Unit, mailed to the mailing address of each Unit or mailed to the mailing address designated by the Owner in writing, together with all expenses incurred by the Association in collecting such unpaid assessments, including attorneys' fees (whether or not suit is instituted). In the event the Association shall bring any suit or action to enforce this Declaration or incurs any costs or collection agency charges to collect any money due under this Declaration, the Owner-defendant shall pay to the Association all costs and expenses incurred by it in connection with such suit or action, with or without litigation, including attorneys' fees. The prevailing party in such suit or action shall recover such amount as the court may determine to be reasonable as attorneys' fees at trial and upon any appeal or petition for review thereof or in connection with any bankruptcy proceedings or special bankruptcy issues or remedies.

8.3 **Responsibility of Owners.** An Owner shall be responsible for the actions of such Owner's family members, contractors, social or business invitees, agents, employees and lessees and shall be equally liable to the Association for any violations by such Persons. Any damages, fines, or charges imposed on an Owner pursuant to this Declaration will be charged to such Owner in accordance with Section 7.5.

8.4 **Nonexclusiveness and Accumulation of Remedies.** An election by the Association to pursue any remedy provided for violation of this Declaration shall not prevent concurrent or subsequent exercise of another remedy permitted hereunder. The remedies provided in this Declaration are not exclusive but shall be in addition to all other remedies, including actions for damages and suits for injunctions and specific performance, available under applicable law to the Association. In addition, any Condominium Owners Association and any aggrieved Owner may bring an action to recover damages or to enjoin, abate or remedy any violation of this Declaration by appropriate legal proceedings.

8.5 **Dispute Resolution.**

(a) **Mediation.**

(i) Except as otherwise provided in this Section, before initiating litigation, arbitration or an administrative proceeding in which the Association and an Owner have an adversarial relationship, the party that intends to initiate litigation, arbitration or an administrative proceeding shall offer to use any dispute resolution program available within Multnomah County, Oregon, that is in substantial compliance with the standards and guidelines adopted under ORS 36.175. The written offer must be hand-delivered or mailed by certified mail, return receipt requested, to the address, contained in the records of the Association, for the other party.

(ii) If the party receiving the offer does not accept the offer within ten (10) days after receipt of the offer, such acceptance to be made by written notice, hand-delivered or mailed by certified mail, return receipt requested, to the address, contained in the records of the Association, for the other party, the initiating party may commence the litigation, arbitration or administrative proceeding. The notice of acceptance of the offer to participate in the program must contain the name, address and telephone number of the body administering the dispute resolution program.

(iii) If a qualified dispute resolution program exists within Multnomah County, Oregon and an offer to use the program is not made as required under paragraph (a) of this Section, then litigation, arbitration or an administrative proceeding may be stayed for thirty (30) days upon a motion of the noninitiating party. If the litigation, arbitration or administrative action is stayed under this paragraph, both parties shall participate in the dispute resolution process.

(iv) Unless a stay has been granted under paragraph (c) of this Section, if the dispute resolution process is not completed within thirty (30) days after receipt of the initial offer, the initiating party may commence litigation, arbitration or an administrative proceeding without regard to whether the dispute resolution is completed.

(v) Once made, the decision of the court, arbitrator or administrative body arising from litigation, arbitration or an administrative proceeding may not be set aside on the grounds that an offer to use

(b) **Costs and Attorneys' Fees.** The fees of any mediator and the costs of mediation shall be divided and paid equally by the parties. Each party shall pay its own attorneys' fees and costs in connection with any mediation. Should any suit, action or arbitration be commenced in connection with any dispute related to or arising out of this Declaration or the Bylaws, to obtain a judicial construction of

any provision of the Declaration or the Bylaws, to rescind this Declaration or the Bylaws or to enforce or collect any judgment or decree of any court or any award obtained during arbitration, the prevailing party shall be entitled to recover its costs and disbursements, together with such investigation, expert witness and attorneys' fees incurred in connection with such dispute, as the court or arbitrator may adjudge reasonable, at trial, in the arbitration, upon any motion for reconsideration, upon petition for review, and on any appeal of such suit, action or arbitration proceeding. The determination of who is the prevailing party and the amount of reasonable attorneys' fees to be paid to the prevailing party shall be decided by the arbitrator (with respect to attorneys' fees incurred prior to and during the arbitration proceeding) and by the court or courts, including any appellate or review court, in which such matter is tried, heard or decided.

(c) **Survival.** The mediation and arbitration agreement set forth in this Section 8.5 shall survive the transfer by any party of its interest or involvement in Harrison Center and any Unit therein and the termination of this Declaration.

## ARTICLE 9

### AMENDMENT AND REPEAL

9.1 **How Proposed.** Amendments to or repeal of this Declaration shall be proposed by at least fifty percent (50%) of the Board. The proposed amendment or repeal must be reduced to writing and shall be included in the notice of any meeting at which action is to be taken thereon or attached to any request for consent to the amendment or repeal.

9.2 **Approval Required.** This Declaration, or any provision thereof, as from time to time in effect with respect to all or any part of Harrison Center, may be amended or repealed by the vote or written consent of all of the voting rights in the Association. All votes or consents of the Board under this Article shall be cast as provided in Section 6.3.

9.3 **Recordation.** Any such amendment or repeal shall become effective only upon Recordation in the Deed Records of Multnomah County, Oregon of a certificate of the president and secretary of the Association setting forth in full the amendment, amendments or repeal so approved and certifying that such amendment, amendments or repeal have been approved in the manner required by this Declaration and ORS 94.590, and acknowledged in the manner provided for acknowledgment of deeds.

9.4 **Regulatory Amendments.** Notwithstanding the provisions of Section 9.2 above, until the Turnover Meeting has occurred, Declarant shall have the right to amend this Declaration or the Bylaws of the Association in order to comply with the requirements of any applicable statute, ordinance or regulation or of the Federal Housing Administration; the United States Department of Veterans Affairs; the Farmers Home Administration of the United States; the Federal National Mortgage Association; the Government National Mortgage Association; the Federal Home Mortgage Loan Corporation, any department, bureau, board, commission or agency of the United States or the State of Oregon; or any corporation wholly owned, directly or indirectly, by the United States or the State of Oregon that insures, guarantees or provides financing for a planned community or lots in a planned community. After the Turnover Meeting, any such amendment shall require the approval of a majority of the voting rights of the Association voting in person, by proxy or by ballot at a meeting or ballot meeting of the Association at which a quorum is represented.

## ARTICLE 10

### MISCELLANEOUS PROVISIONS

10.1 **No Implied Obligations.** Nothing in this Declaration shall be construed to require Declarant to improve or develop any of the Property or to do so for any particular uses.

10.2 **Right to Transfer or Assign Declarant's Rights.** Any or all of the Declarant's rights reserved by Declarant under this Declaration and related obligations may be transferred in whole or in part to other Persons; provided, the transfer shall not reduce an obligation nor enlarge a right beyond that which Declarant then has under this Declaration. No such transfer or assignment shall be effective unless it is in a written instrument signed by Declarant and Recorded. The foregoing sentence shall not preclude Declarant from permitting other Persons to exercise, on a one time or limited basis, any right reserved to Declarant in this Declaration where Declarant does not intend to transfer such right in its entirety, and in such case it shall not be necessary to record any written assignment.

10.3 **Duration.** Unless repealed or terminated in accordance with the provisions of Article 9 this Declaration shall have perpetual duration. If State of Oregon law hereafter limits the period during which covenants may run with the land, then to the extent consistent with such law, this Declaration shall automatically be extended at the expiration of such period for successive periods of 20 years each, unless repealed in accordance with the provisions of Article 9 above.

10.4 **Joint Owners.** In any case in which two or more Persons share the ownership of any Unit, regardless of the form of ownership, the responsibility of such Persons to comply with this Declaration shall be a joint and several responsibility and the act or consent of any one or more of such Persons shall constitute the act or consent of the entire ownership interest; provided, however, that in the event such Persons disagree among themselves as to the manner in which any consent shall be given with respect to a pending matter, any such Person may deliver written notice of such disagreement to the Association, and the right of consent involved shall then be disregarded completely in determining the proportion of consents given with respect to such matter.

10.5 **Lessees and Other Invitees.** Lessees, licensees, social or business invitees, contractors, agents, employees, family members, guests, and other Persons entering the Property under rights derived from an Owner shall comply with all of the applicable provisions of this Declaration. The Owner shall be responsible for obtaining such compliance and shall be liable for any failure of compliance by such Persons in the same manner and to the same extent as if the failure had been committed by such Owner.

10.6 **Nonwaiver.** Failure by the Association to enforce any covenant or restriction herein contained shall in no event be deemed a waiver of the right to do so thereafter.

10.7 **Construction; Severability; Number; Captions.** This Declaration shall be governed and construed under the laws of the State of Oregon. It shall be liberally construed as an entire document to accomplish the purposes thereof as stated in the introductory Sections hereof. Nevertheless, each provision of this Declaration shall be deemed independent and severable, and the invalidity or partial invalidity of any provision shall not affect the validity or enforceability of the remaining part of that or any other provision.

10.8 **Terminology and Captions.** As used in this Declaration, the singular shall include the plural and the plural the singular, and the masculine and neuter shall each include the masculine, feminine and neuter, as the context requires. All captions used herein are intended solely for convenience of reference and shall in no way limit any of the provisions of this Declaration.

10.9 **Notices and Other Documents.** Any notice or other document permitted or required by this Declaration may be delivered either personally or by mail. Delivery by mail shall be deemed made twenty-four (24) hours after having been deposited in the United States mail as certified or registered mail, with postage prepaid, addressed as follows: (a) If to Declarant or the Association, 4640 SW Macadam Avenue, #260, Portland, Oregon 97239; (b) if to a Condominium Owners Association, to the address designated by such Condominium Owners Association in writing, or at the principal office of such Condominium Owners Association; or (c) if to an Owner, to such Owner at the address of such Owner's Unit within the jurisdiction of the Association or such other address as it has registered with the Association. The address of a party may be changed at any time by notice in writing delivered as provided in this Section.

**IN WITNESS WHEREOF**, Declarant has executed this Declaration as of the day and year first written above.

**PORTLAND CENTER INVESTORS LLC**, a Delaware limited liability company

By: Portland Center Mezzanine LLC, a Delaware limited liability company, Manager

By: Portland Center Holding Company LLC, a Delaware limited liability company, Manager

By: S&T-WDD Development, LLC, an Oregon limited liability company, Manager

By: Williams & Dame Development, Inc., an Oregon corporation, Co-Manager

By: S&T Development- Portland Center, LLC, an Oregon limited liability company, Co-Manager

By: Reliance Development, Inc., an Oregon corporation, Member

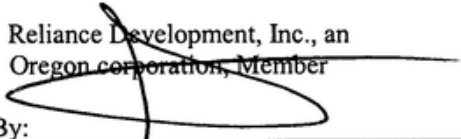
By:   
Scott D. Stehman, Authorized Signer

STATE OF OREGON )  
 )ss.  
COUNTY OF Multnomah )

This instrument was acknowledged before me this 20 day of March, 2006 by Scott D. Stehman, Authorized Signer of Reliance Development, Inc., an Oregon corporation, Member of S&T Development-Portland Center, LLC, an Oregon limited liability company, Co-Manager of S&T-WDD Development, LLC, an Oregon limited liability company, Manager of Portland Center Holding Company LLC, a Delaware limited liability company, Manager of Portland Center Mezzanine LLC, a Delaware limited liability company, Manager of Portland Center Investors LLC, an Oregon limited liability company, on its behalf.

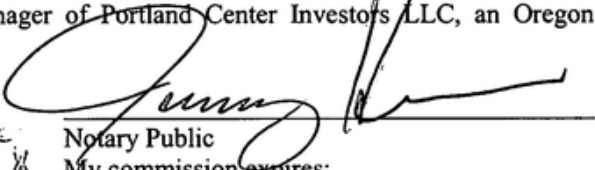

Notary Public  
My commission expires:  
Commission No.:



## EXHIBIT A

### Legal Description of the Property

#### **PARCEL I:**

A part of Block A, SOUTH AUDITORIUM ADDITION TO THE CITY OF PORTLAND, in the County of Multnomah and State of Oregon, described as follows:

Commencing at the Northwest corner of the Finice Caruthers D.L.C.; thence North 71°39'20" East, a distance of 2243.38 feet to a point; thence South 69°08' East a distance of 242 feet, said point being the true point of beginning of the tract to be described; thence from said beginning point North 20°52' East, a distance of 196 feet to a point; thence South 69°08' East, a distance of 282 feet to a point thence North 20°52' East, a distance of 22 feet to a brass screw; thence South 69°08' East, a distance of 176 feet to an iron rod set in the Easterly line of Block A, which iron rod is also on the Westerly line of SW First Avenue; thence South 20°52' West along the Easterly line of Block A, a distance of 188 feet to a Portland Development Commission monument and point of curvature; thence on the arc of a curve right, having a radius of 30 feet and a central angle of 90° the long chord of which bears South 65°52' West 42.43 feet, an arc distance of 47.12 feet to a Portland Development Commission monument on the Southerly line of Block A and the Northerly line of SW Harrison Street; thence North 69°08' West along the Southerly line of Block A, a distance of 428 feet to the true point of beginning.

EXCEPTING THEREFROM that portion dedicated for street use and later established as pedestrian malls, as set forth in City of Portland Resolution No. 370, recorded May 27, 1964 in Book 50, Page 190, and being more particularly described as follows:

A parcel of land in Block A, SOUTH AUDITORIUM ADDITION TO THE CITY OF PORTLAND, in the County of Multnomah and State of Oregon, described as follows:

Beginning at a railroad spike set in the Southerly line of Block A, which railroad spike is also on the Northerly line of SW Harrison Street and from which the Northwest corner of the Finice Caruthers D.L.C. bears North 69°08' West a distance of 496 feet and South 71°39'20" West a distance of 2243.38 feet, and a Portland Development Commission monument bears South 69°08' East a distance of 174 feet; thence from said beginning point North 20°52' East a distance of 196 feet to a railroad spike; thence South 69°08' East a distance of 28 feet to a point; thence South 20°52' West a distance of 196 feet to a railroad spike on the Southerly line of Block A, thence North 69°08' West along the Southerly line of Block A a distance of 28 feet to the point of beginning.

#### **PARCEL II:**

A part of Block B, SOUTH AUDITORIUM ADDITION TO THE CITY OF PORTLAND, in the County of Multnomah and State of Oregon, described as follows:

Commencing at the Northwest corner of the Finice Caruthers D.L.C.; thence North 71°39'20" East, a distance of 2243.38 feet to a point; thence South 69°08' East a distance of 259 feet to a point; thence South 20°52' West a distance of 80 feet to an iron rod on the South line of SW Harrison Street, said iron rod being the true point of beginning of the tract to be described; thence from said beginning point South 69°08' East along the North line of Block B, a distance of 237 feet to a railroad spike; thence South 20°52' West a distance of 196 feet to a railroad spike; thence North 69°08' West a distance of 237 feet to a railroad spike; thence North 20°52' East a distance of 196 feet to the true point of beginning.

**EXHIBIT B**

**BYLAWS OF  
HARRISON CENTER MASTER ASSOCIATION**

## TABLE OF CONTENTS

|           |  | Page |
|-----------|--|------|
| ARTICLE 1 | DEFINITIONS .....                        | 1    |
| 1.1       | Articles of Incorporation .....          | 1    |
| 1.2       | Association .....                        | 1    |
| 1.3       | Declaration .....                        | 1    |
| 1.4       | Incorporation by Reference .....         | 1    |
| ARTICLE 2 | MEMBERSHIP .....                         | 1    |
| 2.1       | Membership .....                         | 1    |
| 2.2       | Membership List .....                    | 1    |
| ARTICLE 3 | MEETINGS AND VOTING .....                | 1    |
| 3.1       | Place of Meetings .....                  | 1    |
| 3.2       | Turnover Meeting .....                   | 2    |
| 3.3       | Annual Meeting .....                     | 2    |
| 3.4       | Special Meetings .....                   | 2    |
| 3.5       | Notice of Meeting .....                  | 2    |
| 3.6       | Quorum .....                             | 2    |
| 3.7       | Voting Rights .....                      | 3    |
| 3.8       | Absentee Ballots .....                   | 3    |
| 3.9       | Majority Vote .....                      | 3    |
| 3.10      | Rules of Order .....                     | 3    |
| ARTICLE 4 | DIRECTORS: MANAGEMENT .....              | 3    |
| 4.1       | Number and Qualification .....           | 3    |
| 4.2       | Interim Directors .....                  | 3    |
| 4.3       | Election and Tenure of Office .....      | 3    |
| 4.4       | Removal of Directors and Vacancies ..... | 4    |
| 4.5       | Powers .....                             | 4    |
| 4.6       | Duties .....                             | 5    |
| 4.7       | Implied Rights; Board Authority .....    | 5    |
| 4.8       | Meetings .....                           | 6    |
| 4.9       | Open Meetings .....                      | 6    |
| 4.10      | Notice of Meetings .....                 | 6    |
| 4.11      | Quorum and Vote .....                    | 7    |
| 4.12      | Liability .....                          | 7    |

|           |  |    |
|-----------|--|----|
| 4.13      | Compensation. ....                             | 7  |
| 4.14      | Executive, Covenants and Other Committees..... | 7  |
| 4.15      | Management. ....                               | 7  |
| ARTICLE 5 | OFFICERS.....                                  | 8  |
| 5.1       | Designation and Qualification.....             | 8  |
| 5.2       | Election and Vacancies. ....                   | 8  |
| 5.3       | Removal and Resignation.....                   | 8  |
| 5.4       | President.....                                 | 8  |
| 5.5       | Secretary. ....                                | 8  |
| 5.6       | Treasurer. ....                                | 9  |
| 5.7       | Compensation of Officers. ....                 | 9  |
| ARTICLE 6 | ASSESSMENTS, RECORDS AND REPORTS.....          | 9  |
| 6.1       | Assessments. ....                              | 9  |
| 6.2       | Records.....                                   | 10 |
| 6.3       | Statement of Assessments Due. ....             | 10 |
| 6.4       | Inspection of Books and Records.....           | 10 |
| 6.5       | Payment of Vouchers. ....                      | 11 |
| 6.6       | Execution of Documents. ....                   | 11 |
| 6.7       | Reports and Audits. ....                       | 11 |
| ARTICLE 7 | INSURANCE.....                                 | 12 |
| 7.1       | Types of Insurance. ....                       | 12 |
|           | (a) Property Damage Insurance. ....            | 12 |
|           | (b) Liability Insurance. ....                  | 12 |
|           | (c) Workers' Compensation Insurance. ....      | 12 |
|           | (d) Fidelity Insurance.....                    | 13 |
| 7.2       | Planned Community Act Requirements.....        | 13 |
| ARTICLE 8 | GENERAL PROVISIONS.....                        | 13 |
| 8.1       | Seal.....                                      | 13 |
| 8.2       | Notice.....                                    | 13 |
| 8.3       | Waiver of Notice.....                          | 13 |
| 8.4       | Action Without Meeting. ....                   | 13 |
| 8.5       | Conflicts. ....                                | 14 |
| ARTICLE 9 | AMENDMENTS TO BYLAWS .....                     | 14 |
| 9.1       | How Proposed.....                              | 14 |
| 9.2       | Adoption. ....                                 | 14 |

9.3 Execution and Recording ..... 14

**BYLAWS OF  
HARRISON CENTER MASTER ASSOCIATION**

**Article 1**

**DEFINITIONS**

1.1 **Articles of Incorporation.** "Articles of Incorporation" means the Articles of Incorporation of the Association.

1.2 **Association.** "Association" means **HARRISON CENTER MASTER ASSOCIATION**, a nonprofit corporation organized and existing under the laws of the State of Oregon.

1.3 **Declaration.** The "Declaration" means the Master Declaration of Covenants, Conditions, Restrictions and Easements for Harrison Center to which these Bylaws are attached, as the same may be subsequently amended or supplemented pursuant to the terms thereof.

1.4 **Incorporation by Reference.** Except as otherwise provided herein, the terms that are defined in Article 1 of the Declaration are used in these Bylaws as therein defined.

**Article 2**

**MEMBERSHIP**

2.1 **Membership.** Every Owner of one or more Units within the Property shall, immediately upon creation of the Association and thereafter during the entire period of such ownership, be a member of the Association. Such membership shall commence, exist and continue simply by virtue of such ownership, shall expire automatically upon termination of such ownership, and need not be confirmed or evidenced by any certificate or acceptance of membership.

2.2 **Membership List.** The Secretary shall maintain at the principal office of the Association a membership list showing the name and address of the Owner of each Unit. The Secretary may accept as satisfactory proof of such ownership a duly executed and acknowledged conveyance, a title insurance policy, or other evidence reasonably acceptable to the Board of Directors.

**Article 3**

**MEETINGS AND VOTING**

3.1 **Place of Meetings.** Meetings of the members of the Association shall be held at such reasonable place convenient to the members as may be designated in the notice of the meeting.

3.2 **Turnover Meeting.** Declarant shall call the first meeting of the Association within ninety (90) days after the recordation of the first Condominium Project plat in Harrison Center. Notice of such meeting shall be given as provided in Section 3.5. If the Declarant fails to call the meeting, the meeting may be called and notice given by any Owner or mortgagee of a Unit. The expense of giving notice shall be paid or reimbursed by the Association. Nothing in this section shall be construed as preventing Declarant from calling the Turnover Meeting before such date or from calling informal, informational meetings of the Association.

3.3 **Annual Meeting.** The annual meeting of the Association for the appointment of directors and for the transaction of such other business as may properly come before the meeting shall be held at such reasonable hour and on such reasonable day as may be established by the Board of Directors. The first annual meeting shall be held within one year after the date of the Turnover Meeting.

3.4 **Special Meetings.** A special meeting of the Association may be called at any time by the President or by a majority of the Board of Directors. Business transacted at a special meeting shall be confined to the purposes stated in the notice of meeting.

3.5 **Notice of Meeting.**

(a) Written or printed notice stating the place, day and hour of the meeting, the items on the agenda, including the general nature of any proposed amendment to the Declaration or these Bylaws, any budget changes, any proposal to remove a director or officer and, in case of a special meeting, the purpose or purposes for which the meeting is called, shall be delivered not less than ten (10) or more than fifty (50) days before the date of the meeting. Such notice shall be given either personally or by mail, by or at the direction of the President, the Secretary, or the persons calling the meeting, to each person or representative entitled to vote at such meeting and to each Condominium Owners Association which shall notify its members of the meeting. Notices to Declarant shall be mailed. If mailed, such notice shall be deemed to be delivered when deposited in the United States mail, with postage fully prepaid thereon, addressed to the member at his or her most recent address as it appears on the records of the Association or to the mailing address of his or her Unit.

(b) When a meeting is adjourned for thirty (30) days or more, or when a redetermination of the persons entitled to receive notice of the adjourned meeting is required by law, notice of the adjourned meeting shall be given as for an original meeting. In all other cases, no notice of the adjournment or of the business to be transacted at the adjourned meeting need be given other than by announcement at the meeting at which such adjournment is taken.

3.6 **Quorum.** At any meeting of the Association, representatives having at least fifty percent (50%) of the voting rights entitled to be cast at such meeting, present in person or by proxy, shall constitute a quorum. When a quorum is once present to organize a meeting, it cannot be broken by the subsequent withdrawal of a person or representative. If any meeting cannot be organized because of a lack of quorum, the persons or representatives who are present, either in person or by proxy, may adjourn the meeting from time to time not less than forty-eight (48) hours or more than thirty (30) days from the time the original meeting was called until a quorum is present.

3.7 **Voting Rights.** Voting rights in the affairs of the Association shall be cast by voting representatives. Each Apartment or Condominium Project shall be allocated one vote for a total of three votes. The owner of each Apartment Project will cast the Apartment Project's vote. Upon the conversion of each Apartment Project to a Condominium Project, the board of directors of the corresponding Condominium Owners Association will act as the Condominium Project's voting representative. Owners of Units will be represented by their voting representative and will not individually have a vote in the affairs of the Association.

3.8 **Absentee Ballots.** A vote may be cast in person or by absentee ballot.

3.9 **Majority Vote.** The vote of a majority of the voting rights entitled to be cast at a meeting at which a quorum is present, shall be necessary for the adoption of any matter voted upon, unless a greater proportion is required by law, by the Declaration, by the Articles of Incorporation, or by these Bylaws.

3.10 **Rules of Order.** Unless other rules of order are adopted by resolution of the Association or the Board of Directors, all meetings of the Association shall be conducted according to the latest edition of Robert's Rules of Order, published by Robert's Rules Association.

#### Article 4

#### DIRECTORS: MANAGEMENT

4.1 **Number and Qualification.** The affairs of the Association shall be governed by a Board of Directors of three (3) persons. All directors, other than interim directors appointed by Declarant or the owner of an Apartment Project within Harrison Center, shall be Owners or co-Owners of Units. For purposes of this section, the officers or any authorized employee or agent of any corporate Owner, the members of any limited liability company and the partners of any partnership shall be considered co-Owners of any Units owned by such corporation or partnership.

4.2 **Interim Directors.** Upon the recording of the Declaration, Declarant, shall appoint an interim board of three (3) directors, who shall serve until replaced by Declarant or until their successors have been replaced as provided below.

4.3 **Election and Tenure of Office.**

(a) At the Turnover Meeting, the interim directors shall resign and three regular directors shall be appointed or elected. The Board of the Association shall be comprised of the three directors, one representing each Apartment Project or Condominium Project in Harrison Center, as appointed by the owners of each Apartment Project or as elected by the board of directors of each Condominium Owners Association, as such Condominium Owners Associations are created.

(b) The interim directors each shall serve a term which expires upon the appointment of regular directors in accordance with Section 4.3(a). Thereafter, except as provided below, each director shall serve terms of two years with the beginning and end of each term corresponding with the fiscal year; provided, directors shall continue to hold office until their successors take office. Directors may serve one or more consecutive terms. At each annual meeting of the Association, directors shall be selected, as provided above, to succeed those directors whose terms are expiring.

4.4 **Removal of Directors and Vacancies.** Any director may be removed, with or without cause, by a vote of the entity that appointed the director. Any director whose removal is sought shall be given written notice prior to any action being taken to remove him or her. Upon removal of a director, a successor shall be appointed in the manner provided in Section 4.3 to fill the vacancy for the remainder of such director's term.

4.5 **Powers.** The Board shall have all the powers provided under Oregon law and all the powers necessary for the administration of the Association's affairs, for furthering the general purposes of the Association, and for performing all responsibilities and exercising all rights of the Association as appropriate for maintaining the Community Facilities as set forth in the Declaration, the Articles, these Bylaws, and as provided by law.

The Board may exercise such powers as it determines, in its business judgment, necessary or desirable to accomplish the goals and objectives of the Association and Harrison Center as set forth in the Declaration and in resolutions the Association may adopt. Specifically, the powers of the Board shall include, without limitation:



(a) operating and maintaining the Community Facilities and facilities over which the Association has operation and control responsibilities or for which the Association has a maintenance easement;

(b) reviewing and regulating all proposed changes in the color and appearance of the exterior of the structures and the landscaping within Harrison Center for the purpose of maintaining a uniform and attractive appearance of such elements;

(c) making or contracting for the making of repairs, additions, and improvements to or alterations of the Community Facilities;

(d) designating, hiring, and dismissing personnel necessary to carrying out the Association's rights and responsibilities and, where appropriate, providing for compensation of such personnel and for the purchase of equipment, supplies, and materials to be used by such personnel in the performance of their duties;

(e) administering and enforcing the terms and conditions of covenants and other agreements concerning particular areas within Harrison Center in accordance with such covenants or agreements;

(f) taking such action as deemed necessary or appropriate to carry out the duties and obligations of the Association as set forth in the Declaration;

(g) fixing and levying assessments in accordance with the Declaration; and

(h) entering into contractual agreements or covenants to share costs with other property or facilities or for maintaining and/or operating shared or mutually beneficial property or facilities.

4.6 **Duties.** Duties of the Board shall include, without limitation:

(a) providing review and approval of proposed alterations to the exterior of the buildings or landscaping within Harrison Center;

(b) managing, operating, repairing and maintaining the Community Facilities;

(c) acquiring or leasing, repairing and replacing fixtures and equipment for the Community Facilities;

(d) paying all taxes and assessments and other costs and charges affecting or related to the Community Facilities and discharging, contesting or protesting liens or charges affecting the Community Facilities;

(e) obtaining and paying the cost of electrical and other utility services the Board deems appropriate for the Community Facilities;

(f) adopting from time to time and enforcing Rules and Regulations relating to use and enjoyment of the Community Facilities by the Owners and their lessees, family members, guests and invitees, and by the public;

(g) obtaining and paying for the cost of legal and accounting services necessary or appropriate for the maintenance and operation of the Community Facilities and the enforcement of this Declaration; provided, however, the Board may not incur or commit the Association to incur legal fees in excess of \$5,000 for any specific litigation or claim matter or enter into any contingent fee contract on any claim in excess of \$100,000 unless the Owners (voting directly and without use of voting representatives) have enacted a resolution authorizing the incurring of such fees by a vote of seventy-five percent (75%) of the voting rights. These limitations shall not be applicable to legal fees incurred in defending the Association or the Board of Directors from claims or litigation brought against them. The limitations set forth in this paragraph shall increase by ten percent on each fifth anniversary of the recording of the Declaration. To the extent required by the Oregon Planned Community Act, the Board shall notify the Owners before instituting litigation or administrative proceedings. With regard to any pending litigation involving the Association, the Board shall periodically report to the Owners as to the status (including settlement offers), progress, and method of finding such litigation. Nothing in this paragraph shall be construed as requiring the Board to disclose any privileged communication between the Association and its counsel.

(h) doing all other acts or things necessary or appropriate to the ordinary and necessary operation and maintenance of the Community Facilities and to preserve and protect the same in the event of any emergency; and

(i) imposing and collecting Assessments in accordance with the Declaration.

4.7 **Implied Rights; Board Authority.** The Association may exercise any right or privilege given to it expressly by the Declaration or these Bylaws, or which may be reasonably implied from, or reasonably necessary to effectuate, any such express right or privilege. Except as otherwise specifically provided in the Declaration, the Articles, these Bylaws, or by law, all rights and powers of the Association may be exercised by the Board.

#### 4.8 **Meetings.**

(a) Meetings of the Board of Directors shall be held at such place as may be designated from time to time by the Board of Directors or other persons calling the meeting.

(b) Annual meetings of the Board of Directors shall be held within thirty (30) days following the adjournment of the annual meetings of the members.

(c) Special meetings of the Board of Directors for any purpose or purposes may be called at any time by the President or by any two directors.

Unless other rules of order are adopted by resolution of the Association or the Board of Directors, all meetings of the Board of Directors shall be conducted according to the latest edition of Robert's Rules of Order, published by Robert's Rules Association.

#### 4.9 **Open Meetings.**

(a) All meetings of the Board of Directors shall be open to Owners except that, in the discretion of the Board, the following matters may be considered in executive session: (i) consultation with legal counsel concerning the rights and duties of the Association regarding existing or potential litigation, or criminal matters; (ii) personnel matters, including salary negotiations and employee discipline; (iii) negotiation of contracts with third parties and (iv) collection of unpaid assessments. Except in the case of an emergency, the Board of Directors shall vote in an open meeting on whether to

meet in executive session. If the Board of Directors votes to meet in executive session, the presiding officer shall state the general nature of the action to be considered and, as precisely as possible, when and under what circumstances the deliberations can be disclosed to Owners. The statement, motion or decision to meet in the executive session shall be included in the minutes of the meeting, and any contract or action considered in executive session shall not become effective unless the Board, following the executive session, reconvenes in open meeting and votes on the contract or action, which shall be reasonably identified in the open meeting and included in the minutes.

(b) Meetings of the Board of Directors may be conducted by telephonic communication or by other means of communication that allows all members of the Board participating to hear each other simultaneously or otherwise to be able to communicate during the meeting. The meeting and notice requirements of this section may not be circumvented by chance, social meetings, or any other means.

#### 4.10 **Notice of Meetings.**

(a) Notice of the time and place of meetings shall be given to each director orally, or delivered in writing personally or by mail or telecopy, at least twenty-four (24) hours before the meeting. Notice shall be sufficient if actually received at the required time or if mailed or telecopied not less than seventy-two (72) hours before the meeting. Notice mailed or telecopied shall be directed to the address shown on the Association's records or to the director's actual address ascertained by the person giving the notice. Such notice need not be given for an adjourned meeting if such time and place is fixed at the meeting adjourned.

(b) Attendance of a director at a meeting shall constitute a waiver of notice of such meeting except when a director attends a meeting for the express purpose of objecting to the transaction of any business because the meeting is not lawfully called or convened.

#### 4.11 **Quorum and Vote.**

(a) Fifty percent (50%) of the directors shall constitute a quorum for the transaction of business. A minority of the directors, in the absence of a quorum, may adjourn from time to time but may not transact any business.

(b) The action of a majority of the directors present at any meeting at which there is a quorum shall be the act of the Board of Directors unless a greater number is required by law, the Declaration, the Articles of Incorporation or these Bylaws.

4.12 **Liability.** Neither a member of the Board of Directors nor an officer of the Association shall be liable to the Association, any Owner or any third party for any damages, loss or prejudice suffered or claimed on account of any action or failure to act in the performance of his or her duties so long as the individual acted in good faith, believed that the conduct was in the best interests of the Association, or at least was not opposed to its best interests, and in the case of criminal proceedings, had no reason to believe the conduct was unlawful. In the event any member of the Board of Directors or any officer of the Association is made a party to any proceeding because the individual is or was a director or officer of the Association, the Association shall defend such individual against such claims and indemnify such individual against liability and expenses incurred to the maximum extent permitted by law. The managing agent of the Association, and its officers and employees, shall not be liable to the Association, the Owners or any third parties on account of any action or failure to act in the performance of its duties as managing agent, except for acts of gross negligence or intentional acts, and the Association shall

indemnify the managing agent and its officers and employees from any such claims, other than for gross negligence or intentional misconduct.

4.13 **Compensation.** No director shall receive any compensation from the Association for acting as such.

4.14 **Executive, Covenants and Other Committees.** Subject to law, the provisions of the Declaration and these Bylaws, the Board of Directors, may appoint an Executive Committee, a Covenants Committee to be responsible for covenant enforcement and such other standing or temporary committees as may be necessary from time to time consisting of Owners and at least one member of the Board of Directors and having such powers as the Board of Directors may designate. Such committees shall hold office at the pleasure of the Board.

4.15 **Management.** The Board may employ a professional management agent or agents for the Association, at such compensation as the Board may establish, to perform such duties and services as the Board shall authorize. The Board may delegate to the management agent, subject to the Board's supervision, such powers as are necessary to perform the management agent's assigned duties but shall not delegate policy-making or budget-adoption authority. Declarant, or an affiliate of Declarant, may be employed as a management agent. The Board may delegate to one of its members the authority to act on its behalf on all matters relating to the duties of any management agent which might arise between meetings of the Board.

## Article 5

### OFFICERS

5.1 **Designation and Qualification.** The officers of the Association shall be the President, the Secretary and the Treasurer. Each officer shall be a member of the Board of Directors. Any two offices, except the offices of President and Secretary, may be held by the same person.

5.2 **Election and Vacancies.** The officers of the Association shall be elected annually by the Board of Directors at the organization meeting of each new Board to serve for one (1) year and until their respective successors are elected. If any office shall become vacant by reason of death, resignation, removal, disqualification or any other cause, the Board of Directors shall elect a successor to fill the unexpired term at any meeting of the Board of Directors.

5.3 **Removal and Resignation.**

(a) Any officer may be removed upon the affirmative vote of a majority of the directors whenever, in their judgment, the best interests of the Association will be served thereby. The removal of an officer shall be without prejudice to the contract rights, if any, of the officer so removed.

(b) Any officer may resign at any time by giving written notice to the Board of Directors, the President or the Secretary of the Association. Any such resignation shall take effect upon receipt of such notice or at any later time specified therein. Unless otherwise specified therein, the acceptance of such resignation shall not be necessary to make it effective, provided, however, that the Board of Directors may reject any postdated resignation by notice in writing to the resigning officer. The effectiveness of such resignation shall not prejudice the contract rights, if any, of the Association against the officer so resigning.

5.4 **President.** The President shall be the chief executive officer of the Association and shall, subject to the control of the Board of Directors, have powers of general supervision, direction and control of the business and affairs of the Association. He or she shall preside at all meetings of the members and of the Board of Directors. He or she shall be an ex officio member of all the standing committees, including the executive committee, if any, shall have the general powers and duties of management usually vested in the office of president of a nonprofit corporation, and shall have such other powers and duties as may be prescribed by the Board of Directors or these Bylaws.

5.5 **Secretary.**

(a) The Secretary shall keep or cause to be kept a book of minutes of all meetings of directors and members showing the time and place of the meeting, whether it was regular or special, and if special, how authorized, the notice given, the names of those present at directors' meetings, the number of memberships present or represented at members' meetings and the proceedings thereof.

(b) The Secretary shall give or cause to be given such notice of the meetings of the members and of the Board of Directors as is required by these Bylaws or by law. The Secretary shall keep the seal of the Association, if any, and affix it to all documents requiring a seal, and shall have such other powers and perform such other duties as may be prescribed by the Board of Directors or these Bylaws.

(c) In the absence or disability of the President, the President's duties and powers shall be performed and exercised by the Secretary.

5.6 **Treasurer.** The Treasurer shall keep and maintain, or cause to be kept and maintained, adequate and correct accounts of the properties and business transactions of the Association, including accounts of its assets, liabilities, receipts and disbursements. The books of accounts shall at all reasonable times be open to inspection by any director. The Treasurer shall deposit or cause to be deposited all moneys and other valuables in the name and to the credit of the Association with such depositories as may be designated by the Board. The Treasurer shall disburse or cause to be disbursed the funds of the Association as may be ordered by the Board, shall render to the President and directors, whenever they request it, an account of all of the Treasurer's transactions as Treasurer and of the financial condition of the Association, and shall have such other powers and perform such other duties as may be prescribed by the Board or these Bylaws.

5.7 **Compensation of Officers.** No officer who is a member of the Board of Directors shall receive any compensation from the Association for acting as an officer, unless such compensation is authorized by a resolution duly adopted by the members. The Board of Directors may fix any compensation to be paid to other officers.

## Article 6

### ASSESSMENTS, RECORDS AND REPORTS

6.1 **Assessments.** As provided in the Declaration, the Association, through its Board of Directors, shall do the following:

(a) Assess and collect from every Assessments in the manner described in the Declaration.

(b) Keep all funds received by the Association as Assessments, other than reserves described in the Declaration, in the Operations Fund and keep all reserves collected pursuant to the Declaration in the Reserve Fund and use such funds only for the purposes described in the Declaration.

(c) From time to time, and at least annually, prepare a budget for the Association, estimating the common expenses expected to be incurred with adequate allowance for reserves based upon the reserve study required by the Declaration, and determine whether the General Assessment should be increased or decreased. Within thirty (30) days after adopting a proposed annual budget, the Board of Directors shall provide a summary of the budget to all Owners. If the Board of Directors fails to adopt a budget, the last adopted annual budget shall continue in effect.

(d) Fix the amount of the General Assessment against each Apartment Project or Condominium Owners Association at least thirty (30) days in advance of each General Assessment period. Written notice of any Assessment shall be sent to the owner of each Apartment Project or Condominium Owners Association when due. The due dates shall be established by the Board of Directors, which may fix a regular flat Assessment payable on a monthly, quarterly, semiannual or annual basis.

(e) Enforce the Assessments in the manner provided in the Declaration.

(f) Keep records of the receipts and expenditures affecting the Operations Fund and Reserve Fund and make the same available for examination by members and their mortgagees at convenient hours, maintain an Assessment roll showing the amount of each Assessment against each Apartment Project or Condominium Owners Association, the amounts paid upon the account and the balance due on the Assessments, and give each entity written notice of each Assessment at least 30 days before the time when such Assessments shall become due and payable.

6.2 **Records.** The Association shall keep within the State of Oregon correct and complete financial records sufficiently detailed for proper accounting purposes, keep minutes of the proceedings of its members, Board of Directors and committees having any of the authority of the Board of Directors, and retain all documents, information and records turned over to the Association by Declarant. All documents, information and records delivered to the Association by Declarant pursuant to ORS 94.616 shall be kept within the State of Oregon.

6.3 **Statement of Assessments Due.** The Association shall provide, within ten (10) business days after receipt of a written request from an owner of an Apartment Project or a Condominium Owners Association, a written statement that provides: (a) the amount of assessments due from the entity and unpaid at the time the request was received, including regular and special assessments, fines and other charges, accrued interest, and late-payment charges; (b) the percentage rate at which interest accrues on assessments that are not paid when due; and (c) the percentage rate used to calculate the charges for late payment or the amount of a fixed-rate charge for late payment. The Association is not required to comply with this section if the Association has commenced litigation by filing a complaint against the owner of an Apartment Project or Condominium Owners Association and the litigation is pending when the statement would otherwise be due.

6.4 **Inspection of Books and Records.** Except as otherwise provided in ORS 94.670(5), during normal business hours or under other reasonable circumstances, the Association shall make reasonably available for examination and, upon written request, available for duplication, by Owners, lenders, and holders of any mortgage of a Unit that make the request in good faith for a proper purpose, current copies of the Declaration, Articles, Bylaws, Rules and Regulations, amendments or supplements to such documents and the books, records, financial statements and current operating budget of the

Association. The Association shall maintain a copy, suitable for purposes of duplication, of each of the following: (a) the Declaration, these Bylaws, the Rules and Regulations and any amendments or supplements thereto, (b) the most recent financial statement of the Association, and (c) the current operating budget of the Association. The Association, within ten (10) business days after receipt of a written request by an Owner, shall furnish copies of such documents to the requesting Owner. Upon written request, the Association shall make such documents, information and records available to such persons for duplication during reasonable hours. The Board of Directors, by resolution, may adopt reasonable rules governing the frequency, time, location, notice and manner of examination and duplication of Association records and the imposition of a reasonable fee for furnishing copies of such documents, information or records. The fee may include reasonable personnel costs for furnishing the documents, information or records.

6.5 **Payment of Vouchers.** The Treasurer or managing agent shall pay all vouchers for all budgeted items and for any nonbudgeted items, up to \$1,000 signed by the President, managing agent, manager or other person authorized by the Board of Directors. Any voucher for nonbudgeted items in excess of \$1,000 shall require the authorization of the President or a resolution of the Board of Directors.

6.6 **Execution of Documents.** The Board of Directors may, except as otherwise provided in the Declaration, Articles of Incorporation, or these Bylaws, authorize any officer or agent to enter into any contract or execute any instrument in the name of and on behalf of the Association. Such authority may be general or confined to specific instances. Unless so authorized by the Board of Directors, no officer, agent, or employee shall have any power or authority to bind the Association by any contract or engagement, to pledge its credit, or to render it liable for any purpose or for any amount.

6.7 **Reports and Audits.** An annual financial statement consisting of a balance sheet and an income and expense statement for the preceding year shall be rendered by the Board of Directors to all Owners and to all mortgagees who have requested the same within ninety (90) days after the end of each fiscal year. Commencing with the fiscal year following the Turnover Meeting, if the General Assessments exceed \$75,000 for the year, then the Board of Directors shall cause such financial statements to be reviewed within 180 days after the end of the fiscal year by an independent certified public accountant licensed in Oregon in accordance with the Statements on Standards for Accounting and Review Services issued by the American Institute of Certified Public Accountants, or if the General Assessments are \$75,000 or less, shall cause such review within 180 days after receipt of a petition requesting such review signed by at least a majority of owners. The Board of Directors need not cause such a review to be performed if so directed by an affirmative vote of at least fifty percent (50%) of the Board. From time to time, the Board of Directors, at the expense of the Association, may obtain an audit of the books and records pertaining to the Association and furnish copies thereof to the members. At any time any Owner or holder of a mortgage may, at their own expense, cause an audit or inspection to be made of the books and records of the Association.

## Article 7

### INSURANCE

7.1 **Types of Insurance.** For the benefit of the Association and the Owners, the Board of Directors shall obtain and maintain at all times, and shall pay for out of the Operations Fund, the following insurance:

(a) **Property Damage Insurance.**

(1) The Association shall maintain a policy or policies of insurance covering loss or damage from fire, with standard extended coverage and "all risk" endorsements, and such other coverages as the Association may deem desirable.

(2) The amount of the coverage shall be for not less than one hundred percent (100%) of the current replacement cost of the improvements on the Community Facilities (exclusive of land, foundation, excavation and other items normally excluded from coverage), subject to a reasonable deductible.

(3) The policy or policies shall include all fixtures and building service equipment to the extent that they are part of the Community Facilities and all personal property and supplies belonging to the Association.

(b) **Liability Insurance.**

(1) The Association shall maintain comprehensive general liability insurance coverage insuring the Declarant, the Association, the Board of Directors, and the managing agent, against liability to the public or to Owners and their invitees or tenants, incident to the operation, maintenance, ownership or use of the Community Facilities, including legal liability arising out of lawsuits related to employment contracts of the Association. There may be excluded from such policy or policies coverage of an Owner (other than as a member of the Association or Board of Directors) for liability arising out of acts or omissions of such Owner and liability incident to the ownership and/or use of the part of the Property as to which such Owner has the exclusive use or occupancy.

(2) Limits of liability under such insurance shall not be less than One Million Dollars (\$1,000,000) on a combined single-limit basis.

(3) Such policy or policies shall be issued on a comprehensive liability basis and shall provide a cross-liability endorsement wherein the rights of named insureds under the policy or policies shall not be prejudiced as respects his, her or their action against another named insured.

(c) **Workers' Compensation Insurance.** The Association shall maintain workers' compensation insurance to the extent necessary to comply with any applicable laws.

(d) **Fidelity Insurance.**

(1) The Board of Directors may cause the Association to maintain blanket fidelity insurance for all officers, directors, trustees and employees of the Association and all other persons handling or responsible for funds of, or administered by, the Association. In the event that the Association has retained a management agent, the Board of Directors may require such agent to maintain fidelity insurance for its officers, employees and agents handling or responsible for funds of, or administered on behalf of, the Association. The cost of such insurance, if any, may be borne by the Association.

(2) The total amount of fidelity insurance coverage required shall be based upon the best business judgment of the Board of Directors.

(3) Such fidelity insurance shall name the Association as obligee and shall contain waivers by the insurers of all defenses based upon the exclusion of persons serving without



compensation from the definition of “employees” or similar terms or expressions. The insurance shall provide that it may not be canceled or substantially modified (including cancellation for nonpayment of premium) without at least ten (10) days’ prior written notice to the Association.

7.2 **Planned Community Act Requirements.** The insurance maintained by the Association shall comply with the requirements of the Oregon Planned Community Act, ORS 94.550 to 94.780.

## Article 8

### GENERAL PROVISIONS

8.1 **Seal.** The Board of Directors may, by resolution, adopt a corporate seal.

8.2 **Notice.** All notices to the Association or to the Board of Directors shall be sent care of the managing agent or, if there is no managing agent, to the principal office of the Association or to such other address as the Board of Directors may hereafter designate from time to time. All notices to members shall be sent to the member’s unit or to such other address as may have been designated by the member from time to time in writing to the Board of Directors.

8.3 **Waiver of Notice.** Whenever any notice to any member or director is required by law, the Declaration, the Articles of Incorporation, or these Bylaws, a waiver of notice in writing signed at any time by the person entitled to notice shall be equivalent to the giving of the notice.

8.4 **Action Without Meeting.** Any action that the law, the Declaration, the Articles of Incorporation or the Bylaws require or permit the members or directors to take at any meeting may be taken without a meeting or ballot meeting if a consent in writing setting forth the action so taken is signed by all of the members or directors entitled to vote on the matter. The consent, which shall have the same effect as a unanimous vote of the members or directors, shall be filed in the records of minutes of the Association.

8.5 **Conflicts.** These Bylaws are intended to comply with the Oregon Planned Community Act, the Oregon Nonprofit Corporation Law, the Declaration and the Articles of Incorporation. In case of any irreconcilable conflict, such statutes and documents shall control over these Bylaws.

## Article 9

### AMENDMENTS TO BYLAWS

9.1 **How Proposed.** Amendments to these Bylaws shall be proposed by a majority of the Board of Directors. The proposed amendment must be reduced to writing and shall be included in the notice of any meeting at which action is to be taken thereon or be attached to any request for consent to the amendment.

9.2 **Adoption.**

(a) A resolution adopting a proposed amendment may be proposed by the Board of Directors and may be approved by the Board at a meeting called for such purpose, or by written consent of the Board members entitled to vote. Members not present at the meeting considering such amendment may express their approval in writing. Any resolution must be approved by members holding a majority of the voting rights. Amendment or repeal of any provision of these Bylaws that is also contained in the

Declaration must be approved by the same voting requirement for amendment of such provision of the Declaration.

(b) Notwithstanding the provisions of the preceding paragraph, until the Turnover Meeting has occurred, Declarant shall have the right to amend these Bylaws in order to comply with the requirements of the Federal Housing Administration, the United States Department of Veterans Affairs, the Farmers Home Administration of the United States, the Federal National Mortgage Association, the Government National Mortgage Association, the Federal Home Mortgage Loan Corporation, any department, bureau, board, commission or agency of the United States or the State of Oregon, or any corporation wholly owned, directly or indirectly, by the United States or the State of Oregon that insures, guarantees or provides financing for a planned community or lots in a planned community. After the Turnover Meeting, any such amendment shall require the approval of a majority of the Board, voting in person, by or by ballot, at a meeting or ballot meeting of the Association at which a quorum is represented.

9.3 **Execution and Recording.** An amendment shall not be effective until certified by the President and Secretary of the Association as being adopted in accordance with these Bylaws and ORS 94.625 and recorded in the Deed Records of Multnomah County, Oregon.

AFTER RECORDING, RETURN TO:

Same as Below

Recorded in MULTNOMAH COUNTY, OREGON  
C. Swick, Deputy Clerk  
E41 65  
Total : 341.00  
ATKLM

2006-080487 05/02/2006 11:24:54am

PREPARED BY:

Howard M. Feuerstein  
Stoel Rives LLP  
900 SW Fifth Avenue, Suite 2600  
Portland, Oregon 97204

**DECLARATION SUBMITTING  
HARRISON WEST CONDOMINIUMS  
TO CONDOMINIUM OWNERSHIP**

**PORTLAND CENTER INVESTORS LLC  
Declarant**

65

**TABLE OF CONTENTS**

|            |  | <b>Page</b> |
|------------|--|-------------|
| Article 1  | DEFINITIONS .....  | 1           |
| 1.1        | “Association” .....  | 1           |
| 1.2        | “Bylaws” .....   | 1           |
| 1.3        | “Condominium” .....  | 1           |
| 1.4        | “Declarant” .....  | 1           |
| 1.5        | “Declaration” .....  | 1           |
| 1.6        | “Living Units” .....   | 1           |
| 1.7        | “Master Declaration” .....                                   | 1           |
| 1.8        | “Mortgage” and “Mortgagee” .....                             | 1           |
| 1.9        | “Parking Units” .....  | 1           |
| 1.10       | “Penthouse Units” .....                                      | 1           |
| 1.11       | “Plat” .....   | 2           |
| 1.12       | “Standard Units” .....                                       | 2           |
| 1.13       | “Townhome Units” .....                                       | 2           |
| 1.14       | Incorporation by Reference.....                              | 2           |
| Article 2  | SUBMISSION OF PROPERTY TO CONDOMINIUM STATUTE .....          | 2           |
| Article 3  | NAME OF CONDOMINIUM .....                                    | 2           |
| Article 4  | UNITS .....  | 2           |
| 4.1        | General Description of Buildings.....                        | 2           |
| 4.2        | General Description, Location and Designation of Units. .... | 2           |
| 4.3        | Boundaries of Units. ....                                    | 2           |
| (a)        | Living Units. ....   | 2           |
| (b)        | Parking Units.....   | 3           |
| Article 5  | GENERAL COMMON ELEMENTS .....                                | 3           |
| Article 6  | LIMITED COMMON ELEMENTS .....                                | 3           |
| Article 7  | ALLOCATION OF UNDIVIDED INTERESTS IN COMMON ELEMENTS .....   | 3           |
| Article 8  | COMMON PROFITS AND EXPENSES; VOTING.....                     | 4           |
| 8.1        | Allocation of Common Profits and Expenses. ....              | 4           |
| 8.2        | Allocation of Voting Rights. ....                            | 4           |
| Article 9  | SERVICE OF PROCESS.....                                      | 4           |
| Article 10 | USE OF PROPERTY .....  | 4           |
| 10.1       | Living Units. ....   | 4           |

|            |   |    |
|------------|---|----|
| 10.2       | Parking Units.....  | 4  |
| Article 11 | MAINTENANCE OF COMMON ELEMENTS .....                      | 5  |
| 11.1       | Responsibility for Maintenance. ....                      | 5  |
| 11.2       | Mortgagee's Rights upon Failure to Maintain. ....         | 5  |
| 11.3       | Rights of City Upon Failure to Maintain. ....             | 5  |
| Article 12 | EASEMENTS .....   | 5  |
| 12.1       | In General.....   | 5  |
| 12.2       | Encroachments. ....                                       | 5  |
| 12.3       | Granting of Easements by Association. ....                | 6  |
| 12.4       | Right of Entry.....                                       | 6  |
| 12.5       | Easements for Declarant.....                              | 6  |
| 12.6       | Master Declaration. ....                                  | 6  |
| Article 13 | APPROVAL BY MORTGAGEES .....                              | 6  |
| 13.1       | Notice of Action.....                                     | 6  |
| 13.2       | Termination and Amendment to Documents. ....              | 7  |
| 13.3       | Additional Approvals. ....                                | 7  |
| 13.4       | Notice to First Mortgagees of Defaults. ....              | 8  |
| Article 14 | ASSOCIATION OF UNIT OWNERS.....                           | 8  |
| 14.1       | Organization.....   | 8  |
| 14.2       | Membership; Board of Directors.....                       | 8  |
| 14.3       | Powers and Duties.....                                    | 8  |
| 14.4       | Adoption of Bylaws, Declarant Control of Association..... | 8  |
| Article 15 | RELOCATION OF BOUNDARIES .....                            | 8  |
| 15.1       | Approval.....   | 8  |
| 15.2       | Powers of Board.....                                      | 9  |
| 15.3       | Amendment. ....   | 9  |
| Article 16 | AMENDMENT .....   | 9  |
| 16.1       | How Proposed. ....  | 9  |
| 16.2       | Approval Required. ....                                   | 9  |
| 16.3       | Recordation. ....   | 9  |
| Article 17 | SEVERABILITY .....  | 10 |
| Article 18 | APPLICABILITY .....                                       | 10 |

**DECLARATION SUBMITTING  
HARRISON WEST CONDOMINIUMS  
TO CONDOMINIUM OWNERSHIP**

**THIS DECLARATION**, pursuant to the provisions of the Oregon Condominium Act, is made and executed this 20<sup>th</sup> day of March, 2006, by **PORTLAND CENTER INVESTORS LLC**, a Delaware limited liability company ("**Declarant**").

Declarant proposes to create a condominium to be known as Harrison West Condominiums, that will be located in the City of Portland, Multnomah County, Oregon. The purpose of this Declaration is to submit the property described in Article 2 below to the condominium form of ownership and use in the manner provided by the Oregon Condominium Act.

**NOW, THEREFORE**, Declarant does hereby declare and provide as follows:

**Article 1**

**DEFINITIONS**

When used in this Declaration the following terms shall have the following meanings:

1.1 "**Association**" means the association of unit owners established pursuant to Article 14 below.

1.2 "**Bylaws**" means the Bylaws of the Harrison West Condominiums Owners Association adopted pursuant to Section 14.4 below as the same may be amended from time to time.

1.3 "**Condominium**" means all of that property submitted to the condominium form of ownership by this Declaration.

1.4 "**Declarant**" means Portland Center Investors LLC, a Delaware limited liability company, and its successors and assigns.

1.5 "**Declaration**" means this Declaration as the same may hereafter be amended.

1.6 "**Living Units**" means Standard Units, Penthouse Units and Townhome Units.

1.7 "**Master Declaration**" means the Master Declaration of Covenants, Conditions, Restrictions and Easements for Harrison Center recorded April 18, 2006 in the Records of Multnomah County, Oregon as Document No. 2006-070734.

1.8 "**Mortgage**" and "**Mortgagee**" mean, respectively, a recorded mortgage, trust deed or contract of sale that creates a lien against a unit, and the holder, beneficiary or vendor of such a mortgage, trust deed or contract of sale.

1.9 "**Parking Units**" means those units for parking of vehicles labeled as such in the attached Exhibit B.

1.10 "**Penthouse Units**" means those units labeled as such in the attached Exhibit B.

1.11 “**Plat**” means the plat of Harrison West Condominiums recorded simultaneously with the recording of this Declaration.

1.12 “**Standard Units**” means those units labeled as such in the attached Exhibit B.

1.13 “**Townhome Units**” means those units labeled as such in the attached Exhibit B.

1.14 **Incorporation by Reference.** Except as otherwise provided in this Declaration, each of the terms defined in ORS 100.005, a part of the Oregon Condominium Act, shall have the meanings set forth in such section.

## Article 2

### SUBMISSION OF PROPERTY TO CONDOMINIUM STATUTE

The property submitted to the Oregon Condominium Act by this Declaration is held by Declarant and conveyed by Declarant in fee simple estate. The land submitted is located in the City of Portland, Multnomah County, Oregon, and is more particularly described in the attached Exhibit A. The property submitted includes the land so described, all buildings, improvements and structures, all easements, and rights and appurtenances located on, belonging to or used in connection with such land.

## Article 3

### NAME OF CONDOMINIUM

The name by which the Condominium shall be known is “**Harrison West Condominiums.**”

## Article 4

### UNITS

4.1 **General Description of Buildings.** The Condominium consists of five buildings of dwelling units. One of such buildings contains 25 stories, with basement and two below-grade parking levels, and four of such buildings contain two stories without basements. The buildings are of concrete construction with concrete siding and built-up roofs.

4.2 **General Description, Location and Designation of Units.** The Condominium contains 195 Living Units and 174 Parking Units for a total of 369 units. The designation, location, description of boundaries and area in square feet of each unit are shown on the Plat and the attached Exhibit B.

#### 4.3 **Boundaries of Units.**

(a) **Living Units.** Each Living Unit shall be bounded by (i) a vertical plane at the center of the air space between adjoining units; (ii) on exterior walls, the inside surface of the exterior skin and a vertical plane at the inside surface of the exterior windows; (iii) for other walls, a vertical plane at the exterior face of the studs; (iv) the top surface of the floor slab; and (v) the interior surfaces of the structural ceilings. Living Units shall include all lath, furring, wallboard, plasterboard, plaster, paneling, tiles, wallpaper, paint, finished flooring and any other materials constituting any part of its finished surfaces, except those portions of the walls, floors or ceilings that materially contribute to the structural or shear capacity of the Condominium. In addition, each such unit shall include the following: (a) All spaces, nonbearing interior partitions, windows, window frames, exterior doors, door frames and all other

fixtures and improvements within the boundaries of the unit; and (b) All outlets of utility and communications service lines, including but not limited to power, light, gas, hot and cold water, heating, refrigeration, air conditioning and waste disposal, security, cable television and telephone, within the boundaries of the unit, but shall not include any part of such lines or ducts themselves.

(b) **Parking Units.** Parking Units are bounded by the surface of floors, ceilings and perimeter walls (if any). Parking Units without perimeter walls are bounded by a vertical plane at the boundary shown on the Plat. Parking Units do not include the floor, ceiling or perimeter walls themselves.

## Article 5

### GENERAL COMMON ELEMENTS

The general common elements consist of all portions of the Condominium that are not part of a unit or a limited common element, including, but not limited to, the following:

5.1 The land, pathways, driveways, fences, grounds, association room and laundry room.

5.2 Pipes, ducts, flues, chutes, conduits, wires and other utility and communications installations to their outlets.

5.3 Roofs, foundations, bearing and shear walls, perimeter walls, beams, columns and girders to the interior surfaces thereof.

5.4 Stairways, landings, hallways, lobbies, elevators, entrances and exits that are not part of a unit.

5.5 All other elements of the buildings and the Condominium necessary or convenient to their existence, maintenance and safety, or normally in common use, except as may be expressly designated in this Declaration as part of a unit or a limited common element.

## Article 6

### LIMITED COMMON ELEMENTS

The following shall constitute limited common elements, the use of which shall be restricted to the units to which they pertain: All patios and decks, each of which shall pertain to the unit that it adjoins as shown on the Plat.

## Article 7

### ALLOCATION OF UNDIVIDED INTERESTS IN COMMON ELEMENTS

Each unit will be entitled to an undivided ownership interest in the common elements determined by the ratio by which the square footage of the particular unit bears to the total square footage of all units combined, as shown on the attached Exhibit B. Each unit's interest in the common elements shall be inseparable from the unit and any conveyance, encumbrance, judicial sale, or other transfer, voluntary or involuntary, of an undivided interest in the common elements shall be void unless the unit to which that interest is allocated is also transferred.



## Article 8

### COMMON PROFITS AND EXPENSES; VOTING

8.1 **Allocation of Common Profits and Expenses.** The common profits and common expenses of the Condominium shall be allocated to the owner of each unit according to the ratio by which the square footage of the particular unit bears to the total square footage of all units combined; provided, however, that upon the sale of each unit to a person other than a successor declarant, the purchaser shall make a contribution to the working capital of the Association equal to two month's of regular Association assessments for the unit as further described in the Bylaws. Except upon termination of the Condominium or as otherwise provided in the Bylaws with respect to damage, destruction or condemnation, any such common profits shall be used solely for the purpose of maintaining, repairing and replacing the common elements or for other expenses or reserves of the Association.

8.2 **Allocation of Voting Rights.** Each unit owner shall be entitled to a vote in the affairs of the Association and for the purposes of this Declaration based upon one vote for each Standard Unit owned by such owner and two votes for each Penthouse Unit and Townhome Unit owned by such owner; provided, however, that Declarant shall have five times the voting rights otherwise allocable to each unit owned by Declarant until the earlier of (a) when Declarant has sold and conveyed to a person other than a successor declarant 75 percent or more of the units in the Condominium, or (b) three years after the date of the first conveyance of a unit to a person other than a successor declarant. No voting rights shall attach to Parking Units. The method of voting shall be as specified in the Bylaws.

## Article 9

### SERVICE OF PROCESS

The designated agent to receive service of process in cases provided in subsection (1) of ORS 100.550 is named in the Condominium Information Report that has been filed in accordance with ORS 100.250(1)(a).

## Article 10

### USE OF PROPERTY

Each unit is to be used for the purposes set forth below. Additional limitations on use are contained in the Bylaws and the rules and regulations adopted pursuant to the Bylaws. Each unit owner shall be bound by each of such documents.

10.1 **Living Units.** Living Units shall be used primarily for residential purposes as defined in the Bylaws.

10.2 **Parking Units.** Parking Units may be used only for parking of vehicles and may be owned only by Declarant, the Association or the owner of a Living Unit in the Condominium. Parking Units may not be used as a residence or by any person other than Declarant, the Association or an owner, occupant or guest of a Living Unit in the Condominium. Transfer of Parking Units by Declarant or by or among unit owners shall be accomplished by deed or other form of real property conveyance instrument.

## Article 11

### MAINTENANCE OF COMMON ELEMENTS

11.1 **Responsibility for Maintenance.** The necessary work to maintain, repair or replace the common elements shall be the responsibility of the board of directors of the Association and shall be carried out as provided in the Bylaws.

11.2 **Mortgagee's Rights upon Failure to Maintain.** If the Mortgagee of any unit determines that the board of directors is not providing an adequate maintenance, repair and replacement program for the common elements, such Mortgagee, at its option, may give a notice to the board of directors by delivering same to the registered agent, setting forth the particular defect that it believes exists in the maintenance, repair and replacement program. If the specified defects are not corrected within 90 days subsequent to receipt of such notice, then the Mortgagee, upon written notice to the registered agent that it is exercising its proxy rights, shall have the right to attend succeeding annual or special meetings of the Association and to cast a vote for each unit on which it holds a Mortgage on all business coming before such meeting. Such proxy rights shall continue until the defects listed on the notice are corrected.

11.3 **Rights of City Upon Failure to Maintain.** The provisions of this Declaration and of the Bylaws regarding the maintenance, repair and replacement of the common elements shall be deemed to be for the benefit of the City of Portland as well as the unit owners, and the City may enforce such provisions by appropriate proceedings at law or in equity. Without limitation to the foregoing, the City may deliver a written notice to the board of directors by delivering the same to the registered agent, setting forth the particular defect that it believes exists in the maintenance, repair and replacement program. If the specified defects are not corrected within 30 days after receipt of the notice, or, if such correction cannot reasonably be completed within such time, the Association fails within such time to commence and pursue the correction with reasonable diligence, then the City may take necessary curative action. In such event, the cost of correction by the City shall constitute a lien against each unit and its interest in the common elements based upon such unit's share of the common expenses as provided in this Declaration.

## Article 12

### EASEMENTS

12.1 **In General.** Each unit has an easement in and through each other unit and the common elements for all support elements and utility, wiring, heat, plumbing, and service elements, and for reasonable access thereto, as required to effectuate and continue proper operation of the Condominium, including, without limitation, easements as required for the electrical wiring and plumbing for each unit. The specific mention or reservation of any easement in this Declaration does not limit or negate the general easement for common elements reserved by law. Each unit owner has an unrestricted right of ingress and egress to his or her unit. This right is perpetual and passes with the ownership of the unit.

12.2 **Encroachments.** Each unit and all common elements shall have an easement over all adjoining units and common elements for the purpose of accommodating any present or future encroachment as a result of engineering errors, construction, reconstruction, repairs, settlement, shifting, or movement of any portion of the property, or any other similar cause, and any encroachment due to building overhang or projection. There shall be valid easements for the maintenance of the encroaching units and common elements so long as the encroachments shall exist, and the rights and obligations of owners shall not be altered in any way by the encroachment. This provision does not relieve a unit owner

of liability in the case of willful misconduct of the unit owner, or relieve Declarant or any contractor, subcontractor or materialman from any liability as a result of failure to adhere to the Plat. The encroachments described in this Section 12.2 shall not be construed to be encumbrances affecting the marketability of title to any unit.

12.3 **Granting of Easements by Association.** Subject to the requirements of ORS 100.405(6), the Association may grant, execute, acknowledge, deliver and record on behalf of the unit owners leases, easements, rights-of-way, licenses, and similar interests affecting the common elements and consent to vacation of roadways within and adjacent to the Condominium. Any such instrument shall be executed by the chairperson and secretary of the Association. No such interest may be granted with regard to a limited common element unless the owners and Mortgagees of the units having the right to use such limited common element consent to and join in the instrument granting the interest.

12.4 **Right of Entry.** The board of directors of the Association, managing agent, manager or any other person authorized by the board of directors shall have the right to enter any unit and limited common element in the case of an emergency originating in or threatening such unit or other condominium property, whether or not the owner is present at the time. Such persons shall also have the right to enter any unit and limited common element for the purpose of performing installations, alterations or repairs to any common element and for the purpose of inspection to verify that the unit owner is complying with the restrictions and requirements described in this Declaration and the Bylaws, provided that requests for entry are made in advance and that such entry is at a time convenient to the owner.

12.5 **Easements for Declarant.** Declarant and Declarant's agents, successors and assigns shall have an easement over and upon the common elements as may be reasonably necessary for the purpose of completing or making repairs to existing structures, for the purpose of carrying out sales and rental activities necessary or convenient for the sale or rental of units, including, without limitation, the right to use the units owned by Declarant as model units and the right to use a unit or the association room, as a sales office, and for the purpose of discharging any other obligation of Declarant or exercising any other special Declarant right, whether arising under the Oregon Condominium Act or reserved in this Declaration or the Bylaws. For a period of ten (10) years following recording of this Declaration, Declarant shall have a right to inspect the common elements of the Condominium and the Association's records regarding inspections and maintenance of the Condominium.

12.6 **Master Declaration.** Pursuant to the Master Declaration, the owners and occupants of Living Units in the Condominium have an easement to use the pool and spa located at the 222 SW Harrison building. Pursuant to the Master Declaration, the Association is required to maintain the exterior appearance and landscaping of the Condominium to the quality standards for Harrison Center and is required to pay a pro rata share of the operating expenses of the Master Association.

### Article 13

#### **APPROVAL BY MORTGAGEES**

13.1 **Notice of Action.** Upon written request to the Association identifying the name and address of the holder, insurer or guarantor and the unit number or address of the unit on which it has (or insures or guarantees) the Mortgage, any such Mortgagee shall be entitled to timely written notice of the following:

(a) Any condemnation or casualty loss that affects a material portion of the Condominium or affects the unit securing its Mortgage.

(b) Any 60-day delinquency in the payment of assessments or charges owed by an owner of any unit on which it holds the Mortgage.

(c) Any lapse, cancellation or material modification of any insurance policy maintained by the Association.

(d) Any proposed action that would require consent of a specified percentage of Mortgagees as required by this article.

### 13.2 **Termination and Amendment to Documents.**

(a) Unless a greater vote is required by this Declaration, the Bylaws or the Oregon Condominium Act, the approval of Mortgagees holding Mortgages on units that have at least 51 percent of the voting rights of units subject to Mortgages shall be required to terminate the legal status of the project as a condominium.

(b) Except when a greater percent is required by the Declaration or Bylaws, or a greater or lesser percent is required by the Oregon Condominium Act, the consent of the Mortgagees holding Mortgages on units that have at least 51 percent of the voting rights of the units subject to Mortgages shall be required for any amendments to the Declaration or Bylaws of a material adverse nature to Mortgagees.

(c) An addition or amendment to the Declaration or Bylaws shall not be considered material or adverse for purposes of Section 13.2(b) if it is for the purpose of correcting technical errors, or for clarification only. Any Mortgagee who receives a written request to approve any termination, additions or amendments and who does not deliver or post to the requesting party a negative response within 60 days shall after it receives proper notice of the proposal, provided the notice was delivered by certified or registered mail, return receipt requested, be deemed to have approved such request.

13.3 **Additional Approvals.** In addition to any other or greater approvals required by the Oregon Condominium Act, this Declaration or the Bylaws, the prior written approval of two-thirds of the holders of first Mortgages on units in the Condominium (based upon one vote for each first Mortgage owned) or unit owners (other than Declarant) must be obtained for the following:

(a) Abandonment or termination of the Condominium regime.

(b) Except as otherwise provided in Section 15.1, any change in the pro rata interest or obligations of any individual unit for (a) purpose of levying assessments or charges or allocating distributions of hazard insurance proceeds or condemnation awards, or (b) determining the pro rata share of ownership of each unit in the common elements.

(c) The partition or subdivision of any unit, except as otherwise provided in Article 15.

(d) Abandonment, partition, subdivision, encumbrance, sale or transfer of the common elements. The granting of easements for public utilities or for other public purposes consistent with the intended use of the common elements by the condominium project shall not be deemed a transfer within the meaning of this clause.

(e) Use of hazard insurance proceeds for losses to any condominium property, whether to units or to common elements, for other than the repair, replacement or reconstruction of such

improvements, except as provided by statute in cases of substantial loss to the units and/or common elements of the condominium project.

13.4 **Notice to First Mortgagees of Defaults.** Any first Mortgagee, upon request, will be entitled to written notification from the Association of any default in the performance by the owner of the Mortgaged unit of any obligation under this Declaration, the rules and regulations or the Bylaws that is not cured within 60 days.

#### Article 14

##### **ASSOCIATION OF UNIT OWNERS**

14.1 **Organization.** Upon the recording of this Declaration an association of unit owners shall be organized to serve as a means through which the unit owners may take action with regard to the administration, management and operation of the Condominium. The name of this association shall be "Harrison West Condominiums Owners Association," and the Association shall be an Oregon nonprofit corporation.

14.2 **Membership; Board of Directors.** Each unit owner shall be a member of the Association. The affairs of the Association shall be governed by a board of directors as provided in the Bylaws.

14.3 **Powers and Duties.** The Association shall have such powers and duties as may be granted to it by the Oregon Condominium Act, including each of the powers set forth in ORS 100.405(4), together with such additional powers and duties afforded it by this Declaration or the Bylaws.

14.4 **Adoption of Bylaws, Declarant Control of Association.** Upon the execution and the recording of this Declaration, Declarant shall adopt Bylaws for the Association, which Bylaws are attached as Exhibit C. Declarant specifically reserves the right to control the Association by appointing the interim directors of the Association until the organizational and turnover meeting of the Association has been held and the unit owners have elected regular directors as provided in Sections 2.2 and 3.4 of the Bylaws. In addition, Declarant shall have the right to consent to any amendment to the Declaration or the Bylaws as provided in Section 16.2 below and Section 9.2 of the Bylaws, and a weighted vote in the Association as provided in Section 8.2 above.

#### Article 15

##### **RELOCATION OF BOUNDARIES**

15.1 **Approval.** The boundaries between adjoining units, including any intervening common elements, may be relocated or eliminated by an amendment to this Declaration. The owners of the affected units shall submit to the board of directors of the Association a proposed amendment that shall identify the units involved, state any reallocations of common element interest, voting rights, common expense liability and right to common profits and contain words of conveyance. The board of directors shall approve the amendment unless it determines within 45 days that the reallocations are unreasonable or the relocation or elimination will impair the structural integrity or mechanical systems of the Condominium or lessen the support of any portion of the Condominium.

15.2 **Powers of Board.** The board of directors of the Association may require the owners of the affected units to submit an opinion of a registered architect or registered professional engineer that the proposed relocation or elimination will not impair the structural integrity or mechanical systems of the

Condominium or lessen the support of any portion of the Condominium. The board of directors of the Association or any agent appointed by the board of directors may supervise the work necessary to effect the boundary relocation or elimination. Any expenses incurred under this section shall be charged to the owners of the units requesting the boundary relocation or elimination.

15.3 **Amendment**. The amendment shall be executed by the owners and Mortgagees of the affected units, certified by the chairperson and secretary of the Association, approved as required by law and recorded in the appropriate records of Multnomah County, Oregon. In addition, plat and floor plans necessary to show the altered boundaries between the adjoining units shall be recorded as required by law.

## Article 16

### **AMENDMENT**

16.1 **How Proposed**. Amendments to the Declaration shall be proposed by either a majority of the board of directors or by unit owners holding thirty percent (30%) or more of the voting rights. The proposed amendment must be reduced to writing and shall be included in the notice of any meeting at which action is to be taken thereon or attached to any request for consent to the amendment.

16.2 **Approval Required**. Except as may otherwise be provided in this Declaration or by the Oregon Condominium Act, this Declaration may be amended if such amendment is approved by unit owners holding 75 percent of the voting rights of the Condominium, without regard to any weighted vote otherwise allocable to units owned by Declarant, and by Mortgagees to the extent required by Article 13. Declarant's prior written consent shall also be required so long as Declarant owns any of the units in the Condominium, but no such consent shall be required after 10 years from the date of conveyance of the first Living Unit to a person other than a successor declarant. Except as otherwise permitted by the Oregon Condominium Act, no amendment may change the size, location, allocation of undivided interest in the common elements, the method of determining liability for common expenses, the method of determining the right to common profits, or the method of determining voting rights of any unit unless such amendment has been approved by the owners and Mortgagees of the affected unit. Any amendment that would limit or diminish any special Declarant rights established in this Declaration or the Bylaws, including, without limitation, any amendment that could unreasonably interfere with the sale, lease or other disposition of units owned by Declarant or that could abridge, modify, eliminate or otherwise affect any right, power, easement, privilege or benefit reserved for Declarant or which would impose any discriminatory charge or fee against Declarant, shall require the written consent of Declarant.

16.3 **Recordation**. The amendment shall be effective upon recordation in the Deed Records of Multnomah County, Oregon, of the Declaration as amended or of the amendment thereto, certified to by the chairperson and secretary of the Association as being adopted in accordance with this Declaration and the provisions of the Oregon Condominium Act, and approved by the county assessor and the Real Estate Commissioner if such approvals are required by the Oregon Condominium Act.

## Article 17

### **SEVERABILITY**

Each provision of this Declaration and the Bylaws shall be deemed independent and severable, and the validity or partial invalidity of any provision shall not affect the validity or enforceability of the remaining part of that or any other provision of this Declaration or the Bylaws.

**Article 18**

**APPLICABILITY**

Each unit owner, including Declarant as to any unsold unit, shall be subject to all of the rights and duties assigned to unit owners under the terms of the Declaration and Bylaws. All present and future owners, tenants, subtenants and occupants of units, and all present and future employees, agents, visitors and licensees of unit owners, shall be subject to and comply with the provisions of this Declaration, the Bylaws and all rules and regulations adopted thereunder, as they may be amended from time to time.

**IN WITNESS WHEREOF**, Declarant has caused this Declaration to be executed as of the day and year first set forth above.

**PORTLAND CENTER INVESTORS LLC**, a Delaware limited liability company

By: Portland Center Mezzanine LLC, a Delaware limited liability company, Manager

By: Portland Center Holding Company LLC, a Delaware limited liability company, Manager

By: S&T-WDD Development, LLC, an Oregon limited liability company, Manager

By: Williams & Dame Development, Inc., an Oregon corporation, Co-Manager

By: S&T Development- Portland Center, LLC, an Oregon limited liability company, Co-Manager

By: ~~Reliance Development, Inc., an Oregon corporation, Member~~

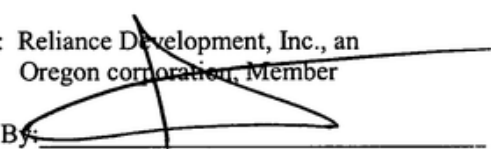
By:   
Scott D. Stehman, Authorized Signer

STATE OF OREGON )  
 )ss.  
COUNTY OF Multnomah )

This instrument was acknowledged before me this 20 day of March, 2006 by Scott D. Stehman, Authorized Signer of Reliance Development, Inc., an Oregon corporation, Member of S&T Development-Portland Center, LLC, an Oregon limited liability company, Co-Manager of S&T-WDD Development, LLC, an Oregon limited liability company, Manager of Portland Center Holding Company LLC, a Delaware limited liability company, Manager of Portland Center Mezzanine LLC, a Delaware limited liability company, Manager of Portland Center Investors LLC, an Oregon limited liability company, on its behalf.

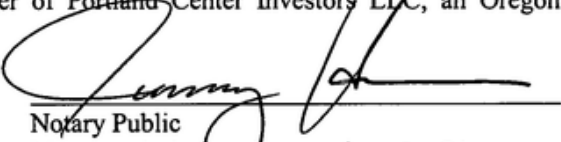
  
\_\_\_\_\_  
Notary Public  
My commission expires: 4-22-06  
Commission No.:



The foregoing Declaration is approved this 1st day of MAY, 2006.

ASSESSOR AND TAX COLLECTOR  
FOR MULTNOMAH COUNTY

By   
\_\_\_\_\_



The foregoing Declaration is approved pursuant to ORS 100.110 this 5<sup>th</sup> day of April 2006 and in accordance with ORS 100.110(7), this approval shall automatically expire if this Declaration is not recorded within two (2) years from this date.

SCOTT W. TAYLOR,  
Real Estate Commissioner

By   
Laurie Skillman

## EXHIBIT A

### Legal Description

The real property situated in the Southwest One-Quarter of Section 3, Township 1 South, Range 1 East, Willamette Meridian, City of Portland, Multnomah County, Oregon, said land being a portion of Lot 2, Block A, "South Auditorium Addition," Multnomah County Plat Records, at the initial point, a found brass screw with a ¾ inch brass washer inscribed "Otak Inc.," said point being on the Northerly right-of-way line of SW Harrison Street and bearing S69°08'00"E, 142.06 feet from a brass screw found at the Southeast corner of Lot 1, Block A, "South Auditorium Addition," Multnomah County Plat Records, said initial point also being the Southwest corner of Parcel 1 as described in Document No. 2005-181406, Multnomah County Deed Records. From said initial point, N20°52'00"E along the Westerly line of said Parcel 1, a distance of 196.00 feet to the Northwesterly corner thereof; thence S69°08'00"E along the Northerly line of said Parcel 1, a distance of 254.00 feet to the Westerly Northeast corner of said Parcel 1; thence S20°52'00"W along the Westerly East line of said Parcel 1, a distance of 196.00 feet to the Northerly right of way line of SW Harrison Street; thence N69°08'00"W along said Northerly right of way line, 254.00 feet to the initial point.

## EXHIBIT B

### Unit Square Footages and Undivided Interests

| <b>Unit</b> | <b>Type</b> | <b>Square Footage</b> | <b>Undivided Interest</b> |
|-------------|-------------|-----------------------|---------------------------|
| 1A          | Standard    | 947                   | 947/186137                |
| 1B          | Standard    | 938                   | 938/186137                |
| 1D          | Standard    | 855                   | 855/186137                |
| 2A          | Standard    | 566                   | 566/186137                |
| 2B          | Standard    | 702                   | 702/186137                |
| 2C          | Standard    | 583                   | 583/186137                |
| 2D          | Standard    | 928                   | 928/186137                |
| 2E          | Standard    | 566                   | 566/186137                |
| 2F          | Standard    | 701                   | 701/186137                |
| 2G          | Standard    | 583                   | 583/186137                |
| 2H          | Standard    | 928                   | 928/186137                |
| 3A          | Standard    | 579                   | 579/186137                |
| 3B          | Standard    | 727                   | 727/186137                |
| 3C          | Standard    | 600                   | 600/186137                |
| 3D          | Standard    | 959                   | 959/186137                |
| 3E          | Standard    | 579                   | 579/186137                |
| 3F          | Standard    | 727                   | 727/186137                |
| 3G          | Standard    | 600                   | 600/186137                |
| 3H          | Standard    | 959                   | 959/186137                |
| 4A          | Standard    | 579                   | 579/186137                |
| 4B          | Standard    | 727                   | 727/186137                |
| 4C          | Standard    | 600                   | 600/186137                |
| 4D          | Standard    | 959                   | 959/186137                |
| 4E          | Standard    | 579                   | 579/186137                |
| 4F          | Standard    | 727                   | 727/186137                |
| 4G          | Standard    | 600                   | 600/186137                |
| 4H          | Standard    | 959                   | 959/186137                |
| 5A          | Standard    | 579                   | 579/186137                |
| 5B          | Standard    | 727                   | 727/186137                |
| 5C          | Standard    | 600                   | 600/186137                |
| 5D          | Standard    | 959                   | 959/186137                |
| 5E          | Standard    | 579                   | 579/186137                |
| 5F          | Standard    | 727                   | 727/186137                |
| 5G          | Standard    | 600                   | 600/186137                |
| 5H          | Standard    | 959                   | 959/186137                |

| <b>Unit</b> | <b>Type</b> | <b>Square Footage</b> | <b>Undivided Interest</b> |
|-------------|-------------|-----------------------|---------------------------|
| 6A          | Standard    | 579                   | 579/186137                |
| 6B          | Standard    | 727                   | 727/186137                |
| 6C          | Standard    | 600                   | 600/186137                |
| 6D          | Standard    | 959                   | 959/186137                |
| 6E          | Standard    | 579                   | 579/186137                |
| 6F          | Standard    | 727                   | 727/186137                |
| 6G          | Standard    | 600                   | 600/186137                |
| 6H          | Standard    | 959                   | 959/186137                |
| 7A          | Standard    | 579                   | 579/186137                |
| 7B          | Standard    | 727                   | 727/186137                |
| 7C          | Standard    | 600                   | 600/186137                |
| 7D          | Standard    | 959                   | 959/186137                |
| 7E          | Standard    | 579                   | 579/186137                |
| 7F          | Standard    | 727                   | 727/186137                |
| 7G          | Standard    | 600                   | 600/186137                |
| 7H          | Standard    | 959                   | 959/186137                |
| 8A          | Standard    | 579                   | 579/186137                |
| 8B          | Standard    | 727                   | 727/186137                |
| 8C          | Standard    | 600                   | 600/186137                |
| 8D          | Standard    | 959                   | 959/186137                |
| 8E          | Standard    | 579                   | 579/186137                |
| 8F          | Standard    | 727                   | 727/186137                |
| 8G          | Standard    | 600                   | 600/186137                |
| 8H          | Standard    | 959                   | 959/186137                |
| 9A          | Standard    | 579                   | 579/186137                |
| 9B          | Standard    | 727                   | 727/186137                |
| 9C          | Standard    | 600                   | 600/186137                |
| 9D          | Standard    | 959                   | 959/186137                |
| 9E          | Standard    | 579                   | 579/186137                |
| 9F          | Standard    | 727                   | 727/186137                |
| 9G          | Standard    | 600                   | 600/186137                |
| 9H          | Standard    | 959                   | 959/186137                |
| 10A         | Standard    | 579                   | 579/186137                |
| 10B         | Standard    | 727                   | 727/186137                |
| 10C         | Standard    | 600                   | 600/186137                |
| 10D         | Standard    | 959                   | 959/186137                |
| 10E         | Standard    | 579                   | 579/186137                |
| 10F         | Standard    | 727                   | 727/186137                |
| 10G         | Standard    | 600                   | 600/186137                |
| 10H         | Standard    | 959                   | 959/186137                |

| <b>Unit</b> | <b>Type</b> | <b>Square Footage</b> | <b>Undivided Interest</b> |
|-------------|-------------|-----------------------|---------------------------|
| 11A         | Standard    | 579                   | 579/186137                |
| 11B         | Standard    | 727                   | 727/186137                |
| 11C         | Standard    | 600                   | 600/186137                |
| 11D         | Standard    | 959                   | 959/186137                |
| 11E         | Standard    | 579                   | 579/186137                |
| 11F         | Standard    | 727                   | 727/186137                |
| 11G         | Standard    | 600                   | 600/186137                |
| 11H         | Standard    | 959                   | 959/186137                |
| 12A         | Standard    | 579                   | 579/186137                |
| 12B         | Standard    | 727                   | 727/186137                |
| 12C         | Standard    | 600                   | 600/186137                |
| 12D         | Standard    | 959                   | 959/186137                |
| 12E         | Standard    | 579                   | 579/186137                |
| 12F         | Standard    | 727                   | 727/186137                |
| 12G         | Standard    | 600                   | 600/186137                |
| 12H         | Standard    | 959                   | 959/186137                |
| 14A         | Standard    | 581                   | 581/186137                |
| 14B         | Standard    | 731                   | 731/186137                |
| 14C         | Standard    | 603                   | 603/186137                |
| 14D         | Standard    | 964                   | 964/186137                |
| 14E         | Standard    | 581                   | 581/186137                |
| 14F         | Standard    | 731                   | 731/186137                |
| 14G         | Standard    | 603                   | 603/186137                |
| 14H         | Standard    | 964                   | 964/186137                |
| 15A         | Standard    | 583                   | 583/186137                |
| 15B         | Standard    | 735                   | 735/186137                |
| 15C         | Standard    | 606                   | 606/186137                |
| 15D         | Standard    | 969                   | 969/186137                |
| 15E         | Standard    | 583                   | 583/186137                |
| 15F         | Standard    | 735                   | 735/186137                |
| 15G         | Standard    | 606                   | 606/186137                |
| 15H         | Standard    | 969                   | 969/186137                |
| 16A         | Standard    | 583                   | 583/186137                |
| 16B         | Standard    | 735                   | 735/186137                |
| 16C         | Standard    | 606                   | 606/186137                |
| 16D         | Standard    | 969                   | 969/186137                |
| 16E         | Standard    | 583                   | 583/186137                |
| 16F         | Standard    | 735                   | 735/186137                |
| 16G         | Standard    | 606                   | 606/186137                |
| 16H         | Standard    | 969                   | 969/186137                |

| <b>Unit</b> | <b>Type</b> | <b>Square Footage</b> | <b>Undivided Interest</b> |
|-------------|-------------|-----------------------|---------------------------|
| 17A         | Standard    | 585                   | 585/186137                |
| 17B         | Standard    | 740                   | 740/186137                |
| 17C         | Standard    | 609                   | 609/186137                |
| 17D         | Standard    | 974                   | 974/186137                |
| 17E         | Standard    | 585                   | 585/186137                |
| 17F         | Standard    | 740                   | 740/186137                |
| 17G         | Standard    | 609                   | 609/186137                |
| 17H         | Standard    | 975                   | 975/186137                |
| 18A         | Standard    | 585                   | 585/186137                |
| 18B         | Standard    | 740                   | 740/186137                |
| 18C         | Standard    | 609                   | 609/186137                |
| 18D         | Standard    | 974                   | 974/186137                |
| 18E         | Standard    | 585                   | 585/186137                |
| 18F         | Standard    | 740                   | 740/186137                |
| 18G         | Standard    | 609                   | 609/186137                |
| 18H         | Standard    | 975                   | 975/186137                |
| 19A         | Standard    | 587                   | 587/186137                |
| 19B         | Standard    | 744                   | 744/186137                |
| 19C         | Standard    | 611                   | 611/186137                |
| 19D         | Standard    | 980                   | 980/186137                |
| 19E         | Standard    | 587                   | 587/186137                |
| 19F         | Standard    | 744                   | 744/186137                |
| 19G         | Standard    | 611                   | 611/186137                |
| 19H         | Standard    | 980                   | 980/186137                |
| 20A         | Standard    | 587                   | 587/186137                |
| 20B         | Standard    | 744                   | 744/186137                |
| 20C         | Standard    | 611                   | 611/186137                |
| 20D         | Standard    | 980                   | 980/186137                |
| 20E         | Standard    | 587                   | 587/186137                |
| 20F         | Standard    | 744                   | 744/186137                |
| 20G         | Standard    | 611                   | 611/186137                |
| 20H         | Standard    | 980                   | 980/186137                |
| 21A         | Standard    | 587                   | 587/186137                |
| 21B         | Standard    | 744                   | 744/186137                |
| 21C         | Standard    | 611                   | 611/186137                |
| 21D         | Standard    | 980                   | 980/186137                |
| 21E         | Standard    | 587                   | 587/186137                |
| 21F         | Standard    | 744                   | 744/186137                |
| 21G         | Standard    | 611                   | 611/186137                |
| 21H         | Standard    | 980                   | 980/186137                |

| <b>Unit</b> | <b>Type</b> | <b>Square Footage</b> | <b>Undivided Interest</b> |
|-------------|-------------|-----------------------|---------------------------|
| 22A         | Standard    | 587                   | 587/186137                |
| 22B         | Standard    | 744                   | 744/186137                |
| 22C         | Standard    | 611                   | 611/186137                |
| 22D         | Standard    | 980                   | 980/186137                |
| 22E         | Standard    | 587                   | 587/186137                |
| 22F         | Standard    | 744                   | 744/186137                |
| 22G         | Standard    | 611                   | 611/186137                |
| 22H         | Standard    | 980                   | 980/186137                |
| 23A         | Standard    | 587                   | 587/186137                |
| 23B         | Standard    | 744                   | 744/186137                |
| 23C         | Standard    | 611                   | 611/186137                |
| 23D         | Standard    | 980                   | 980/186137                |
| 23E         | Standard    | 587                   | 587/186137                |
| 23F         | Standard    | 744                   | 744/186137                |
| 23G         | Standard    | 611                   | 611/186137                |
| 23H         | Standard    | 980                   | 980/186137                |
| 24A         | Penthouse   | 1277                  | 1277/186137               |
| 24B         | Penthouse   | 1653                  | 1653/186137               |
| 24C         | Penthouse   | 1277                  | 1277/186137               |
| 24D         | Penthouse   | 1653                  | 1653/186137               |
| 25A         | Penthouse   | 1277                  | 1277/186137               |
| 25B         | Penthouse   | 1653                  | 1653/186137               |
| 25C         | Penthouse   | 1277                  | 1277/186137               |
| 25D         | Penthouse   | 1653                  | 1653/186137               |
| 26A         | Penthouse   | 1277                  | 1277/186137               |
| 26B         | Penthouse   | 1653                  | 1653/186137               |
| 26C         | Penthouse   | 1277                  | 1277/186137               |
| 26D         | Penthouse   | 1653                  | 1653/186137               |
| TH1         | Townhouse   | 1184                  | 1184/186137               |
| TH2         | Townhouse   | 1184                  | 1184/186137               |
| TH3         | Townhouse   | 1184                  | 1184/186137               |
| TH4         | Townhouse   | 1184                  | 1184/186137               |
| TH5         | Townhouse   | 1184                  | 1184/186137               |
| TH6         | Townhouse   | 1184                  | 1184/186137               |
| TH7         | Townhouse   | 1184                  | 1184/186137               |
| TH8         | Townhouse   | 1184                  | 1184/186137               |
| TH9         | Townhouse   | 1184                  | 1184/186137               |
| TH10        | Townhouse   | 1184                  | 1184/186137               |
| TH11        | Townhouse   | 1184                  | 1184/186137               |
| TH12        | Townhouse   | 1184                  | 1184/186137               |

| <b>Unit</b> | <b>Type</b> | <b>Square Footage</b> | <b>Undivided Interest</b> |
|-------------|-------------|-----------------------|---------------------------|
| P1          | Parking     | 131                   | 131/186137                |
| P2          | Parking     | 135                   | 135/186137                |
| P3          | Parking     | 134                   | 134/186137                |
| P4          | Parking     | 131                   | 131/186137                |
| P5          | Parking     | 136                   | 136/186137                |
| P6          | Parking     | 130                   | 130/186137                |
| P7          | Parking     | 134                   | 134/186137                |
| P8          | Parking     | 137                   | 137/186137                |
| P9          | Parking     | 138                   | 138/186137                |
| P10         | Parking     | 141                   | 141/186137                |
| P11         | Parking     | 154                   | 154/186137                |
| P12         | Parking     | 137                   | 137/186137                |
| P13         | Parking     | 236                   | 236/186137                |
| P14         | Parking     | 216                   | 216/186137                |
| P15         | Parking     | 230                   | 230/186137                |
| P16         | Parking     | 229                   | 229/186137                |
| P17         | Parking     | 231                   | 231/186137                |
| P18         | Parking     | 221                   | 221/186137                |
| P19         | Parking     | 231                   | 231/186137                |
| P20         | Parking     | 225                   | 225/186137                |
| P21         | Parking     | 231                   | 231/186137                |
| P22         | Parking     | 225                   | 225/186137                |
| P23         | Parking     | 247                   | 247/186137                |
| P24         | Parking     | 209                   | 209/186137                |
| P25         | Parking     | 171                   | 171/186137                |
| P26         | Parking     | 207                   | 207/186137                |
| P27         | Parking     | 123                   | 123/186137                |
| P28         | Parking     | 131                   | 131/186137                |
| P29         | Parking     | 137                   | 137/186137                |
| P30         | Parking     | 137                   | 137/186137                |
| P31         | Parking     | 137                   | 137/186137                |
| P32         | Parking     | 132                   | 132/186137                |
| P33         | Parking     | 136                   | 136/186137                |
| P34         | Parking     | 136                   | 136/186137                |
| P35         | Parking     | 131                   | 131/186137                |
| P36         | Parking     | 135                   | 135/186137                |
| P37         | Parking     | 135                   | 135/186137                |
| P38         | Parking     | 204                   | 204/186137                |
| P39         | Parking     | 194                   | 194/186137                |
| P40         | Parking     | 173                   | 173/186137                |



| <b>Unit</b> | <b>Type</b> | <b>Square Footage</b> | <b>Undivided Interest</b> |
|-------------|-------------|-----------------------|---------------------------|
| P41         | Parking     | 131                   | 131/186137                |
| P42         | Parking     | 99                    | 99/186137                 |
| P43         | Parking     | 180                   | 180/186137                |
| P44         | Parking     | 228                   | 228/186137                |
| P45         | Parking     | 228                   | 228/186137                |
| P46         | Parking     | 180                   | 180/186137                |
| P47         | Parking     | 185                   | 185/186137                |
| P48         | Parking     | 234                   | 234/186137                |
| P49         | Parking     | 185                   | 185/186137                |
| P50         | Parking     | 189                   | 189/186137                |
| P51         | Parking     | 239                   | 239/186137                |
| P52         | Parking     | 183                   | 183/186137                |
| P53         | Parking     | 192                   | 192/186137                |
| P54         | Parking     | 239                   | 239/186137                |
| P55         | Parking     | 191                   | 191/186137                |
| P56         | Parking     | 181                   | 181/186137                |
| P57         | Parking     | 205                   | 205/186137                |
| P58         | Parking     | 181                   | 181/186137                |
| P59         | Parking     | 121                   | 121/186137                |
| P60         | Parking     | 121                   | 121/186137                |
| P61         | Parking     | 239                   | 239/186137                |
| P62         | Parking     | 216                   | 216/186137                |
| P63         | Parking     | 239                   | 239/186137                |
| P64         | Parking     | 162                   | 162/186137                |
| P65         | Parking     | 212                   | 212/186137                |
| P66         | Parking     | 234                   | 234/186137                |
| P67         | Parking     | 168                   | 168/186137                |
| P68         | Parking     | 152                   | 152/186137                |
| P69         | Parking     | 134                   | 134/186137                |
| P70         | Parking     | 138                   | 138/186137                |
| P71         | Parking     | 136                   | 136/186137                |
| P72         | Parking     | 128                   | 128/186137                |
| P73         | Parking     | 135                   | 135/186137                |
| P74         | Parking     | 136                   | 136/186137                |
| P75         | Parking     | 135                   | 135/186137                |
| P76         | Parking     | 136                   | 136/186137                |
| P77         | Parking     | 148                   | 148/186137                |
| P78         | Parking     | 156                   | 156/186137                |
| P79         | Parking     | 160                   | 160/186137                |
| P80         | Parking     | 155                   | 155/186137                |

| <b>Unit</b> | <b>Type</b> | <b>Square Footage</b> | <b>Undivided Interest</b> |
|-------------|-------------|-----------------------|---------------------------|
| P81         | Parking     | 154                   | 154/186137                |
| P82         | Parking     | 145                   | 145/186137                |
| P83         | Parking     | 222                   | 222/186137                |
| P84         | Parking     | 212                   | 212/186137                |
| P85         | Parking     | 224                   | 224/186137                |
| P86         | Parking     | 211                   | 211/186137                |
| P87         | Parking     | 263                   | 263/186137                |
| P88         | Parking     | 211                   | 211/186137                |
| P89         | Parking     | 224                   | 224/186137                |
| P90         | Parking     | 209                   | 209/186137                |
| P91         | Parking     | 226                   | 226/186137                |
| P92         | Parking     | 224                   | 224/186137                |
| P93         | Parking     | 211                   | 211/186137                |
| P94         | Parking     | 145                   | 145/186137                |
| P95         | Parking     | 140                   | 140/186137                |
| P96         | Parking     | 243                   | 243/186137                |
| P97         | Parking     | 215                   | 215/186137                |
| P98         | Parking     | 231                   | 231/186137                |
| P99         | Parking     | 223                   | 223/186137                |
| P100        | Parking     | 256                   | 256/186137                |
| P101        | Parking     | 196                   | 196/186137                |
| P102        | Parking     | 238                   | 238/186137                |
| P103        | Parking     | 219                   | 219/186137                |
| P104        | Parking     | 237                   | 237/186137                |
| P105        | Parking     | 219                   | 219/186137                |
| P106        | Parking     | 176                   | 176/186137                |
| P107        | Parking     | 176                   | 176/186137                |
| P108        | Parking     | 192                   | 192/186137                |
| P109        | Parking     | 128                   | 128/186137                |
| P110        | Parking     | 134                   | 134/186137                |
| P111        | Parking     | 134                   | 134/186137                |
| P112        | Parking     | 137                   | 137/186137                |
| P113        | Parking     | 135                   | 135/186137                |
| P114        | Parking     | 135                   | 135/186137                |
| P115        | Parking     | 136                   | 136/186137                |
| P116        | Parking     | 136                   | 136/186137                |
| P117        | Parking     | 134                   | 134/186137                |
| P118        | Parking     | 133                   | 133/186137                |
| P119        | Parking     | 137                   | 137/186137                |
| P120        | Parking     | 208                   | 208/186137                |

| <b>Unit</b> | <b>Type</b> | <b>Square Footage</b> | <b>Undivided Interest</b> |
|-------------|-------------|-----------------------|---------------------------|
| P121        | Parking     | 205                   | 205/186137                |
| P122        | Parking     | 179                   | 179/186137                |
| P123        | Parking     | 110                   | 110/186137                |
| P124        | Parking     | 102                   | 102/186137                |
| P125        | Parking     | 106                   | 106/186137                |
| P126        | Parking     | 180                   | 180/186137                |
| P127        | Parking     | 230                   | 230/186137                |
| P128        | Parking     | 228                   | 228/186137                |
| P129        | Parking     | 180                   | 180/186137                |
| P130        | Parking     | 176                   | 176/186137                |
| P131        | Parking     | 236                   | 236/186137                |
| P132        | Parking     | 193                   | 193/186137                |
| P133        | Parking     | 182                   | 182/186137                |
| P134        | Parking     | 238                   | 238/186137                |
| P135        | Parking     | 191                   | 191/186137                |
| P136        | Parking     | 184                   | 184/186137                |
| P137        | Parking     | 240                   | 240/186137                |
| P138        | Parking     | 189                   | 189/186137                |
| P139        | Parking     | 181                   | 181/186137                |
| P140        | Parking     | 227                   | 227/186137                |
| P141        | Parking     | 239                   | 239/186137                |
| P142        | Parking     | 181                   | 181/186137                |
| P143        | Parking     | 139                   | 139/186137                |
| P144        | Parking     | 137                   | 137/186137                |
| P145        | Parking     | 240                   | 240/186137                |
| P146        | Parking     | 194                   | 194/186137                |
| P147        | Parking     | 180                   | 180/186137                |
| P148        | Parking     | 238                   | 238/186137                |
| P149        | Parking     | 189                   | 189/186137                |
| P150        | Parking     | 187                   | 187/186137                |
| P151        | Parking     | 234                   | 234/186137                |
| P152        | Parking     | 186                   | 186/186137                |
| P153        | Parking     | 171                   | 171/186137                |
| P154        | Parking     | 188                   | 188/186137                |
| P155        | Parking     | 154                   | 154/186137                |
| P156        | Parking     | 128                   | 128/186137                |
| P157        | Parking     | 134                   | 134/186137                |
| P158        | Parking     | 135                   | 135/186137                |
| P159        | Parking     | 137                   | 137/186137                |
| P160        | Parking     | 136                   | 136/186137                |

| <b>Unit</b> | <b>Type</b>  | <b>Square Footage</b> | <b>Undivided Interest</b> |
|-------------|--------------|-----------------------|---------------------------|
| P161        | Parking      | 128                   | 128/186137                |
| P162        | Parking      | 143                   | 143/186137                |
| P163        | Parking      | 135                   | 135/186137                |
| P164        | Parking      | 138                   | 138/186137                |
| P165        | Parking      | 146                   | 146/186137                |
| P166        | Parking      | 140                   | 140/186137                |
| P167        | Parking      | 141                   | 141/186137                |
| P168        | Parking      | 136                   | 136/186137                |
| P169        | Parking      | 143                   | 143/186137                |
| P170        | Parking      | 141                   | 141/186137                |
| P171        | Parking      | 140                   | 140/186137                |
| P172        | Parking      | 142                   | 142/186137                |
| P173        | Parking      | 150                   | 150/186137                |
| P174        | Parking      | 133                   | 133/186137                |
|             | <b>TOTAL</b> | <b>186137</b>         | <b>1</b>                  |

**EXHIBIT C**

**BYLAWS**

**OF**

**HARRISON WEST CONDOMINIUMS OWNERS ASSOCIATION**

**TABLE OF CONTENTS**

|           |   | <b>Page</b> |
|-----------|---|-------------|
| ARTICLE 1 | PLAN OF CONDOMINIUM OWNERSHIP .....       | 1           |
| 1.1       | Name and Location .....                   | 1           |
| 1.2       | Principal Office .....                    | 1           |
| 1.3       | Purposes .....                            | 1           |
| 1.4       | Applicability of Bylaws .....             | 1           |
| 1.5       | Composition of Association .....          | 1           |
| 1.6       | Incorporation .....                       | 1           |
| 1.7       | Definitions .....                         | 1           |
| ARTICLE 2 | MEETINGS OF ASSOCIATION .....             | 1           |
| 2.1       | Place of Meetings .....                   | 1           |
| 2.2       | Organizational and Turnover Meeting ..... | 1           |
| 2.3       | Annual Meetings .....                     | 2           |
| 2.4       | Special Meetings .....                    | 2           |
| 2.5       | Notice of Meetings .....                  | 2           |
| 2.6       | Voting .....                              | 2           |
| 2.7       | Absentee Ballots and Proxies .....        | 2           |
| 2.8       | Fiduciaries and Joint Owners .....        | 3           |
| 2.9       | Tenants and Contract Vendors .....        | 3           |
| 2.10      | Quorum of Unit Owners .....               | 3           |
| 2.11      | Majority Vote .....                       | 3           |
| 2.12      | Order of Business .....                   | 3           |
| 2.13      | Rules of Order .....                      | 4           |
| 2.14      | Ballot Meetings .....                     | 4           |
| ARTICLE 3 | BOARD OF DIRECTORS .....                  | 5           |
| 3.1       | Number and Qualification .....            | 5           |
| 3.2       | Interim Directors .....                   | 5           |
| 3.3       | Transitional Committee .....              | 5           |
| 3.4       | Election and Term of Office .....         | 5           |
| 3.5       | Vacancies .....                           | 5           |
| 3.6       | Removal of Directors .....                | 6           |
| 3.7       | Powers and Duties .....                   | 6           |
| 3.8       | Managing Agent or Manager .....           | 8           |

|           |   |    |
|-----------|---|----|
| 3.9       | Contracts Entered into by Declarant or Interim Board.....             | 8  |
| 3.10      | Organizational Meeting.....   | 9  |
| 3.11      | Regular and Special Meetings.....                                     | 9  |
| 3.12      | Open Meetings .....   | 9  |
| 3.13      | Waiver of Notice .....  | 9  |
| 3.14      | Quorum of Board of Directors .....                                    | 10 |
| 3.15      | Compensation.....   | 10 |
| 3.16      | Liability and Indemnification of Directors, Officers and Manager..... | 10 |
| 3.17      | Insurance .....   | 10 |
| ARTICLE 4 | OFFICERS.....   | 11 |
| 4.1       | Designation .....   | 11 |
| 4.2       | Election of Officers .....  | 11 |
| 4.3       | Removal of Officers .....   | 11 |
| 4.4       | Chairperson .....   | 11 |
| 4.5       | Secretary.....  | 11 |
| 4.6       | Treasurer .....   | 11 |
| 4.7       | Execution of Instruments .....  | 11 |
| 4.8       | Compensation of Officers .....  | 12 |
| ARTICLE 5 | BUDGET, EXPENSES AND ASSESSMENTS.....                                 | 12 |
| 5.1       | Budget .....  | 12 |
| 5.2       | Determination of Common Expenses .....                                | 12 |
| 5.3       | Assessment of Common Expenses.....                                    | 12 |
|           | (a) Obligation to pay.....  | 12 |
|           | (b) Working capital fund.....   | 13 |
|           | (c) Commencement of regular operating expense assessments.....        | 13 |
|           | (d) Commencement of assessment for replacement reserves. ....         | 13 |
| 5.4       | Special or Extraordinary Assessments .....                            | 13 |
|           | (a) Special Assessments for Capital Improvements. ....                | 13 |
|           | (b) Other Special or Extraordinary Assessments. ....                  | 14 |
| 5.5       | Replacement Reserves.....   | 14 |
|           | (a) Establishment of Account. ....                                    | 14 |
|           | (b) Funding of Account. ....  | 14 |
|           | (c) Reserve Studies. ....   | 14 |
|           | (d) Use of Reserve Funds.....   | 15 |
|           | (e) Sale of Units. ....   | 15 |

|           |  |    |
|-----------|--|----|
| 5.6       | Default in Payment of Assessments .....                                    | 15 |
| 5.7       | Foreclosure of Liens for Unpaid Assessments .....                          | 15 |
| 5.8       | Statement of Assessments .....   | 16 |
| 5.9       | Priority of Lien; First Mortgages .....                                    | 16 |
| 5.10      | Voluntary Conveyance .....   | 16 |
| ARTICLE 6 | RECORDS AND AUDITS .....   | 16 |
| 6.1       | General Records .....  | 16 |
| 6.2       | Financial Records and Accounts .....                                       | 16 |
| 6.3       | Assessment Roll .....  | 16 |
| 6.4       | Payment of Vouchers .....  | 17 |
| 6.5       | Reports and Audits .....   | 17 |
| 6.6       | Notice of Sale, Mortgage, Rental or Lease .....                            | 17 |
| 6.7       | Availability of Records .....  | 17 |
| 6.8       | Statement of Assessments Due .....   | 17 |
| ARTICLE 7 | MAINTENANCE AND USE OF CONDOMINIUM PROPERTY .....                          | 18 |
| 7.1       | Maintenance and Repair .....   | 18 |
|           | (a) Units .....  | 18 |
|           | (b) Common elements .....  | 18 |
| 7.2       | Additions, Alterations or Improvements .....                               | 18 |
| 7.3       | Damage or Destruction by Casualty of Condominium Property .....            | 19 |
| 7.4       | Condemnation .....   | 19 |
|           | (a) Complete Taking .....  | 20 |
|           | (b) Partial Taking .....   | 20 |
| 7.5       | Restrictions and Requirements Respecting Use of Condominium Property ..... | 20 |
|           | (a) Residential use .....  | 20 |
|           | (b) Use of common elements .....   | 20 |
|           | (c) Offensive or unlawful activities .....                                 | 20 |
|           | (d) Animals .....  | 21 |
|           | (e) Exterior lighting or noisemaking devices and antennas .....            | 21 |
|           | (f) Windows, decks, patios and outside walls .....                         | 21 |
|           | (g) Signs .....  | 21 |
|           | (h) Trash .....  | 21 |
|           | (i) Insurance .....  | 21 |
|           | (j) Water beds .....   | 21 |
|           | (k) Washing Machines .....   | 22 |



|            |   |    |
|------------|---|----|
|            | (l) Association rules and regulations.....                                  | 22 |
| 7.6        | Leasing and Rental of Units.....  | 22 |
| 7.7        | Failure to Follow Maintenance Manual.....                                   | 23 |
| 7.8        | Abatement and Enjoining of Violations.....                                  | 23 |
| ARTICLE 8  | INSURANCE.....  | 24 |
| 8.1        | Types of Insurance.....   | 24 |
|            | (a) Property Damage Insurance.....  | 24 |
|            | (b) Liability Insurance.....  | 24 |
|            | (c) Workers' Compensation Insurance.....                                    | 25 |
|            | (d) Fidelity Insurance.....   | 25 |
|            | (e) Directors' and Officers' Liability Insurance.....                       | 25 |
|            | (f) Insurance by Unit Owners.....   | 25 |
| 8.2        | Other Insurance Requirements.....   | 26 |
| 8.3        | Optional Provisions.....  | 27 |
| 8.4        | FannieMae and GNMA Requirements.....  | 27 |
| ARTICLE 9  | AMENDMENTS TO BYLAWS.....   | 27 |
| 9.1        | How Proposed.....   | 27 |
| 9.2        | Adoption.....   | 27 |
| 9.3        | Execution and Recording.....  | 28 |
| ARTICLE 10 | DISPUTE RESOLUTION.....   | 28 |
| 10.1       | Claims Other than for Defective or Negligent Construction or Condition..... | 28 |
|            | (a) Mediation.....  | 28 |
|            | (b) Arbitration.....  | 29 |
|            | (c) Excluded Matters.....   | 29 |
|            | (d) Costs and Attorneys' Fees.....  | 29 |
| 10.2       | Claims for Negligent or Defective Construction or Condition.....            | 29 |
|            | (a) Initial Dispute Resolution Procedures.....                              | 30 |
|            | (b) Mediation.....  | 30 |
|            | (c) Arbitration.....  | 31 |
|            | (d) Third Parties.....  | 31 |
|            | (e) Attorney Fees.....  | 31 |
|            | (f) Confidentiality.....  | 31 |
|            | (g) Time Periods within which Claims must be Asserted.....                  | 31 |
| 10.3       | Arbitration.....  | 31 |
|            | (a) Selection of Arbitrator.....  | 31 |

|            |                                   |    |
|------------|-----------------------------------|----|
|            | (b) Consolidated Arbitration..... | 32 |
|            | (c) Discovery .....               | 32 |
|            | (d) Evidence.....                 | 32 |
| 10.4       | Survival. ....                    | 32 |
| ARTICLE 11 | MISCELLANEOUS .....               | 32 |
| 11.1       | Notices.....                      | 32 |
| 11.2       | Waiver .....                      | 32 |
| 11.3       | Action Without a Meeting.....     | 32 |
| 11.4       | Invalidity; Number; Captions..... | 33 |
| 11.5       | Conflicts .....                   | 33 |

**BYLAWS OF  
HARRISON WEST CONDOMINIUMS OWNERS ASSOCIATION**

**Article 1**

**PLAN OF CONDOMINIUM OWNERSHIP**

1.1 **Name and Location.** These are the bylaws of the **HARRISON WEST CONDOMINIUMS OWNERS ASSOCIATION** (the "Association"). **HARRISON WEST CONDOMINIUMS** (the "Condominium") is located in the City of Portland, Multnomah County, Oregon, and has been submitted to the Oregon Condominium Act by a declaration recorded simultaneously with these Bylaws (the "Declaration"). The location of the Condominium is more specifically described in the Declaration.

1.2 **Principal Office.** The principal office of the Association shall be located at such address as may be designated by the board of directors from time to time.

1.3 **Purposes.** This Association is formed under the provisions of the Oregon Condominium Act to serve as the means through which the unit owners may take action with regard to the administration, management and operation of the Condominium.

1.4 **Applicability of Bylaws.** The Association, all unit owners, and all persons using the Condominium property shall be subject to these Bylaws and to all rules and regulations that may be adopted pursuant to these Bylaws.

1.5 **Composition of Association.** The Association shall be composed of all the unit owners of the Condominium, including Portland Center Investors LLC, a Delaware limited liability company, and its successors and assigns (the "Declarant"), and the Association, itself, to the extent any of these own any unit or units of the Condominium.

1.6 **Incorporation.** The Association shall be incorporated under the Oregon Non-Profit Corporation Law. The Articles of Incorporation of the Association shall be consistent with the Declaration and these Bylaws, and these Bylaws shall constitute the bylaws of the incorporated association.

1.7 **Definitions.** The definitions contained in or adopted by the Declaration shall be applicable to these Bylaws.

**Article 2**

**MEETINGS OF ASSOCIATION**

2.1 **Place of Meetings.** The Association shall hold meetings at such suitable place convenient to the unit owners as may be designated by the board of directors from time to time.

2.2 **Organizational and Turnover Meeting.** Within three years after the date of conveyance of the first unit to a person other than a successor declarant, or within ninety (90) days after Declarant has sold and conveyed to a person other than a successor declarant seventy-five percent (75%) or more of the units in the Condominium, whichever is earlier, the Declarant shall call the first meeting of

the unit owners to organize the Association and to elect directors. Notice of such meeting shall be given to all owners as provided in Section 2.5. If Declarant fails to call the meeting, the meeting may be called and notice given by any unit owner or Mortgagee of a unit. The expense of giving notice shall be paid or reimbursed by the Association. At the meeting, Declarant shall deliver to the Association such information and documents as may be required by the Oregon Condominium Act. Nothing in this Section shall be construed as preventing the Declarant from calling the organizational and turnover meeting prior to such date, or from calling informal, informational meetings of the unit owners.

2.3 **Annual Meetings.** The annual meetings of the Association shall be held on such date each year as may be established by the board of directors from time to time, or if the board does not establish such a date, then in the month of February at such hour and on such date as the chairperson may designate, or if the chairperson should fail to designate such date by the first day of February then on the last Tuesday in February. The annual meetings shall be for the purpose of electing directors and for the transaction of such other business as may properly come before the meeting.

2.4 **Special Meetings.** Special meetings of the Association may be called by the chairperson or by a majority of the board of directors, and must be called by such officers upon receipt of a written request from unit owners owning at least thirty percent (30%) of the voting rights stating the purpose of the meeting. Business transacted at a special meeting shall be confined to the purposes stated in the notice of meeting.

2.5 **Notice of Meetings.** Notice of the annual meeting and all other meetings of the Association stating the time and place and the purpose or purposes for which the meeting is being called shall be given by the chairperson or secretary. Such notice shall be in writing and mailed not less than ten (10) days nor more than fifty (50) days prior to the date of the meeting to each unit owner at his or her address as it appears on the books of the Association and to any first Mortgagee requesting such notice. Proof of such mailing shall be given by the affidavit of the person giving the notice. For a period of ten (10) years following recording of the Declaration, notices of meetings (including agendas) shall also be given to Declarant in the same manner as given to unit owners, and Declarant or a representative of Declarant shall be entitled to attend such meetings. Notice of meeting may be waived by any unit owner before or after meetings. When a meeting is adjourned for less than thirty (30) days, no notice of the adjourned meeting need be given other than by announcement at the meeting at which such adjournment takes place.

2.6 **Voting.** Each owner shall have one vote for each Standard Unit of the Condominium owned by such unit owner and two votes for each Penthouse Unit and Townhome Unit owned by such unit owner; provided, however, that Declarant shall have five times the voting rights otherwise allocable to each such unit owned by Declarant until the earlier of (a) when Declarant has sold and conveyed to a person other than a successor declarant 75 percent or more of the units in the Condominium, or (b) three years after the date of the first conveyance of a unit to a person other than a successor declarant. No voting rights shall attach to Parking Units. The Declarant shall be entitled to vote as the unit owner of any then existing Living Units retained by the Declarant, and the board of directors shall be entitled to vote on behalf of any Living Unit that has been acquired by or on behalf of the Association; provided, however, that the board of directors shall not be entitled to vote such units in any election of directors.

2.7 **Absentee Ballots and Proxies.** A vote may be cast in person, by absentee ballot or by proxy. A proxy given by a unit owner to any person who represents such owner at meetings of the Association shall be in writing and signed by such owner, and shall be filed with the secretary at any time prior to or at the start of the meeting. An owner may not revoke a proxy given pursuant to this Section except by actual notice of revocation to the person presiding over a meeting or to the board of directors if a vote is being conducted by written ballot in lieu of a meeting. A proxy shall not be valid if it is undated

or purports to be revocable without notice. A proxy shall terminate one year after its date unless the proxy specifies a shorter term. Every proxy shall automatically cease upon sale of the unit by its owner. A unit owner may pledge or assign such owner's voting rights to a Mortgagee. In such a case, the Mortgagee or its designated representative shall be entitled to receive all notices to which the unit owner is entitled under these Bylaws and to exercise the unit owner's voting rights from and after the time that the Mortgagee shall give written notice of such pledge or assignment to the board of directors. Any first Mortgagee may designate a representative to attend all or any meetings of the Association.

2.8 **Fiduciaries and Joint Owners.** An executor, administrator, guardian or trustee may vote, in person or by proxy, at any meeting of the Association with respect to any unit owned or held in such capacity, whether or not the same shall have been transferred to his or her name; provided, that such person shall satisfy the secretary that he or she is the executor, administrator, guardian or trustee, holding such unit in such capacity. Whenever any unit is owned by two or more persons jointly, according to the records of the Association, the vote or proxy of such unit may be exercised by any one of the owners then present, in the absence of protest by a co-owner. In the event of disagreement among the co-owners, the vote of such unit shall be disregarded completely in determining the proportion of votes given with respect to such matter unless a valid court order establishes the authority of a co-owner to vote.

2.9 **Tenants and Contract Vendors.** Unless otherwise expressly stated in the rental agreement or lease, all voting rights allocated to a unit shall be exercised by the owner/landlord. Unless otherwise stated in the contract, all voting rights allocated to a unit shall be exercised by the vendee of any recorded land sale contract on the unit.

2.10 **Quorum of Unit Owners.** At any meeting of the Association, members holding twenty percent (20%) of the voting rights, present in person or by proxy, shall constitute a quorum. The subsequent joinder of a unit owner in the action taken at a meeting by signing and concurring in the minutes of the meeting shall constitute the presence of such person for the purpose of determining a quorum. When a quorum is once present to organize a meeting, it cannot be broken by the subsequent withdrawal of a unit owner or owners. If any meeting of members cannot be organized because of a lack of quorum, the members who are present, either in person or by proxy, may adjourn the meeting from time to time until a quorum is present. The quorum for the adjourned meeting shall be reduced to ten percent (10%) of the voting rights, present in person or by proxy.

2.11 **Majority Vote.** The vote of the holders of more than fifty percent (50%) of the voting rights, present in person or by proxy at a meeting at which a quorum is constituted, shall be binding upon all unit owners for all purposes except where a higher percentage vote is required by law, by the Declaration or by these Bylaws.

2.12 **Order of Business.** The order of business at annual meetings of the Association shall be:

- (a) Calling of the roll and certifying of proxies;
- (b) Proof of notice of meeting or waiver of notice;
- (c) Reading of minutes of preceding meeting;
- (d) Reports of officers;
- (e) Reports of committees, if any;
- (f) Election of directors;

- (g) Unfinished business;
- (h) New business; and
- (i) Adjournment.

2.13 **Rules of Order.** Unless other rules of order are adopted by resolution of the Association or the board of directors, all meetings of the Association shall be conducted according to the latest edition of *Robert's Rules of Order* published by Robert's Rules Association.

2.14 **Ballot Meetings.**

(a) At the discretion of the board of directors, any action that may be taken at any annual, regular or special meeting of the Association may be taken without a meeting if the Association delivers a written ballot to every member that is entitled to vote on the matter; provided, however, that a ballot meeting may not substitute for the organizational and turnover meeting described in Section 2.2 or, if a majority of the units are the principal residences of the occupants, for the annual meetings of the Association. The written ballot shall set forth each proposed action and provide an opportunity to vote for or against each proposed action.

(b) The board of directors shall provide owners with at least ten (10) days' notice before written ballots are mailed or otherwise delivered. If, at least three (3) days before written ballots are scheduled to be mailed or otherwise distributed, at least ten percent (10%) of the owners petition the board of directors requesting secrecy procedures, a written ballot must be accompanied by a secrecy envelope, a return identification envelope to be signed by the owner and instructions for marking and returning the ballot. The notice shall state the general subject matter of the vote, the right of the owners to request secrecy procedures, the date after which ballots may be distributed, the date and time by which any petition must be received by the board requesting secrecy procedures and the address where any petition must be received. Notwithstanding the applicable provisions of paragraph (c) of this Section, written ballots that are returned in secrecy envelopes may not be examined or counted before the deadline for returning ballots has passed.

(c) If approval of a proposed action would otherwise require a meeting at which a certain quorum must be present and at which a certain percentage of total votes cast is required to authorize the action, the proposal will be deemed to be approved when the date for return of ballots has passed, a quorum of unit owners has voted and the required percentage of approving votes has been received. Otherwise, the proposal shall be deemed to be rejected. If approval of a proposed action otherwise would require a meeting at which a specified percentage of unit owners must authorize the action, the proposal shall be deemed to be approved when the percentage of total votes cast in favor of the proposal equals or exceeds such required percentage. The proposal shall be deemed to be rejected when the number of votes cast in opposition renders approval impossible or when both the date for return of ballots has passed and such required percentage has not been met. Except as otherwise provided in paragraph (b) of this Section, votes may be counted from time to time before the final return date to determine whether the proposal has passed or failed by the votes already cast on the date they are entered.

(d) All solicitations for votes by written ballot shall state the number of responses needed to meet any applicable quorum requirement and the total percentage of votes needed for approval. All such solicitations for votes shall specify the period during which the Association will accept written ballots for counting, which period shall end on the earliest of (i) the date on which the Association has received a sufficient number of approving ballots to pass the proposal, or (ii) the date on which the Association has received a sufficient number of disapproving ballots to render the proposal impossible of

passage, or (iii) a date certain on which all ballots must be returned to be counted. A written ballot may not be revoked.

### Article 3

#### **BOARD OF DIRECTORS**

3.1 **Number and Qualification.** The affairs of the Association shall be governed by a board of directors composed of three (3) interim directors or five (5) to seven (7) regular directors, as provided in Sections 3.2 and 3.4 of this Article. All directors, other than interim directors appointed by Declarant, shall be owners or co-owners of units of the Condominium. For purposes of this Section, the officers members, managers, partners and any duly appointed employees of any corporation, limited liability company or partnership shall be considered co-owners of any units owned by such corporation, limited liability company or partnership.

3.2 **Interim Directors.** Upon the recording of the Declaration submitting the Condominium to the Oregon Condominium Act the Declarant shall appoint an interim board of three (3) directors, who shall serve until replaced by Declarant or their successors have been elected by the unit owners as provided below.

3.3 **Transitional Committee.** Unless the organizational and turnover meeting described in Section 2.2 above has already been held, Declarant shall call a meeting of the unit owners for the purpose of forming a transitional committee. The meeting shall be called within sixty (60) days of conveyance to persons other than Declarant of fifty percent (50%) of the units. Declarant shall give notice of the meeting as provided in Section 2.5 above. The committee shall consist of two or more members elected by the unit owners other than Declarant and not more than one representative of Declarant. The members shall serve until the organizational and turnover meeting. The transitional committee shall be advisory only and its purpose shall be to enable ease of transition from control of the administration of the Association by the Declarant to control by the unit owners. The committee shall have access to the information, documents and records that Declarant must turn over to the unit owners at the time of the organizational and turnover meeting. If Declarant fails to call the meeting to elect a transitional committee within the time specified, the meeting may be called and notice given by any unit owner.

3.4 **Election and Term of Office.** At the first organizational and turnover meeting called by Declarant pursuant to Section 2.2 of these Bylaws, the interim directors shall resign and five (5) successors shall be elected, two to serve until the next annual meeting and three to serve until the second annual meeting after their election. The candidates receiving the greatest number of votes shall be elected to the two-year terms. Thereafter, at the expiration of the initial term of office of each respective director, his or her successor shall be elected to serve for a term of two (2) years, so that the term of not less than one-third of the directors shall expire annually. Directors shall hold office until their respective successors have been elected by the unit owners. Election shall be by plurality. Upon a majority vote of the membership present in person or by proxy at a meeting called for such purpose, the number of directors may be increased to seven (7) directors. Upon such increase, two additional directors shall be elected, one to serve until the next annual meeting and the other to serve until the second annual meeting after their election. Thereafter, each successor shall be elected to serve for a two-year term.

3.5 **Vacancies.** Vacancies in the board of directors caused by any reason other than the removal of a director by a vote of the Association shall be filled by vote of the majority of the remaining directors, even though they may constitute less than a quorum, or by a sole remaining director. Each person so elected shall be a director until a successor is elected to fill the unexpired term at the next

annual meeting of the Association or the next special meeting of the Association called for that purpose. Vacancies in interim directors shall be filled by Declarant.

3.6 **Removal of Directors.** At any regular or special meeting of the Association duly called, any one or more of the directors, other than interim directors, may be removed with or without cause by a majority vote of the unit owners present in person or by proxy, and a successor shall be elected at that meeting to fill the vacancy thus created. The notice of any such meeting shall state that such removal is to be considered, and any director whose removal has been proposed shall be given an opportunity to be heard at that meeting.

3.7 **Powers and Duties.** The board of directors shall have all of the powers and duties necessary for the administration of the affairs of the Association, except such powers and duties as by law or by the Declaration or by these Bylaws may not be delegated to the board of directors by the unit owners; provided, however, that the board of directors may not take any action that could unreasonably interfere with the sale, lease or other disposition of units owned by Declarant or that could abridge, modify, eliminate or otherwise affect any right, power, easement, privilege or benefit reserved for Declarant or which would impose any discriminatory charge or fee against Declarant, without the prior written consent of Declarant. The powers and duties to be exercised by the board of directors shall include, but shall not be limited to the following:

(a) Operation, care, upkeep, maintenance, repair and replacement of the general and limited common elements and Association property.

(b) Determination of the amounts required for operation, maintenance and other affairs of the Association, and the making of such expenditures.

(c) Preparation and adoption of budgets, preparation, review and update of reserve studies and assessment and collection of the common expenses, all in accordance with the provisions of these Bylaws.

(d) Employment and dismissal of such personnel as necessary for the efficient maintenance, upkeep and repair of the common elements.

(e) Employment of legal, accounting or other personnel for reasonable compensation to perform such services as may be required for the proper administration of the Association; provided, however, the board may not incur or commit the Association to incur legal fees in excess of \$5,000 for any specific litigation or claim matter or enter into any contingent fee contract on any claim in excess of \$100,000 unless the unit owners have enacted a resolution authorizing the incurring of such fees or contract by a vote of seventy-five percent (75%) of the total voting rights of the Association. These limitations shall not be applicable to legal fees incurred in defending the Association and the board of directors from claims or litigation brought against them. The limitations set forth in this paragraph shall increase by ten percent on each fifth anniversary of the recording of the Declaration. To the extent required by ORS 100.490, the board shall notify the owners prior to instituting litigation or administrative proceedings. With regard to any pending litigation involving the Association, the board shall periodically report to the unit owners as to the status (including settlement offers), progress, and method of funding such litigation. Nothing in this paragraph shall be construed as requiring the board to disclose any privileged communication between the Association and its counsel.

(f) Opening of bank accounts on behalf of the Association and designating the signatories required therefor.



(g) Preparation and distribution of annual financial statements in accordance with these Bylaws and annual preparation and filing of all required income tax returns or forms for the Association.

(h) Borrowing money on behalf of the Association when required in connection with the operation, care, upkeep, and maintenance of the common elements and Association property; provided, however, that (i) the consent of the unit owners shall be required for the borrowing of any sum in excess of an amount or amounts, aggregated for the calendar year in question, exceeding fifteen percent (15%) of the estimated budget of the Association for that calendar year to cover the operation, care upkeep and maintenance of the common elements, and (ii) no lien to secure repayment of any sum borrowed may be created on any unit or its appurtenant interest in the common elements without the consent of the owner of such unit. If any sum borrowed by the board of directors on behalf of the Association pursuant to the authority contained in this paragraph is not repaid by the Association, a unit owner who pays to the creditor such proportion thereof equal to his interest in the common elements shall be entitled to obtain from the creditor a release of any judgment or other lien which the creditor shall have filed or shall have the right to file against such owner's unit.

(i) Purchasing units of the Condominium at foreclosure or other judicial sales in the name of the Association, or its designee, on behalf of all the unit owners as provided in these Bylaws, and selling, leasing, mortgaging, voting the votes appurtenant to (other than for the election of directors), or otherwise dealing with units of the Condominium acquired by the Association or its designee on behalf of all the unit owners.

(j) Obtaining insurance or bonds pursuant to the provisions of these Bylaws and at least annually reviewing the insurance coverage of the Association.

(k) Making additions and improvements to, or alterations of, the common elements; provided, however, that no such project may be undertaken by the board if the total cost will exceed the amount of \$20,000 unless the unit owners have enacted a resolution authorizing the project by a majority vote of the members, except that no such vote shall be required for work that is urgently needed for life, safety or structural integrity reasons. This limitation shall not be applicable to maintenance, repairs or replacement undertaken pursuant to paragraph (a) above. The limitation set forth in this paragraph shall increase by \$1,000 on each anniversary of the recording of the Declaration.

(l) Modify, close, remove, eliminate or discontinue the use of a general common element facility or improvement or portion of the common element landscaping, except that modification, closure, removal, elimination or discontinuance other than on a temporary basis of any swimming pool, spa or recreation or community building must be approved by at least a majority of the unit owners voting on such matter at a meeting or by written ballot held or conducted in accordance with these Bylaws. The board of directors shall establish policies and procedures for use or assignment of storage lockers.

(m) Designating one or more committees which, to the extent provided in the resolution designating the committee, shall have the powers of the board of directors in the management of the affairs of the Association. At least one member of each committee shall be a member of the board of directors.

(n) Enforcement by legal means of the provisions of the Oregon Condominium Act, the Declaration, these Bylaws and any rules and regulations adopted hereunder. Nothing in these Bylaws shall be construed as requiring the Association to take any specific action to enforce violations.

(o) Maintain a current mailing address for the Association, file an Annual Report and any amendment in accordance with ORS 100.250, and maintain and keep current the information required to enable the Association to comply with ORS 100.480(7).

(p) Subject to the restrictions in subsection (e) above, initiate or intervene in litigation or administrative proceedings (including mediation under Article 10 of these Bylaws) in the name of the Association, and without joining the individual unit owners, as permitted under ORS 100.405(4)(e) and (11); provided that no litigation or administrative proceeding may be initiated on a matter relating to or affecting the unit or interest of a unit owner unless the unit owner has consented in writing to such action after full disclosure of the potential cost, duration and outcomes of the proposed litigation or administrative proceeding.

(q) Establish, periodically update, and implement a Maintenance Manual that identifies those components of the common elements requiring periodic maintenance, including a maintenance manual defining how and when such maintenance should be performed and setting forth the estimated cost of such maintenance. The Maintenance Manual shall provide for not less than annual inspections of the property for evidence of water intrusion or other needed repairs by a knowledgeable independent party, and the board shall reasonably address any matters revealed by the inspection. For a period of ten (10) years following recording of the Declaration, Declarant shall be notified prior to the inspections, shall have a right for Declarant or its employees or contractors to be present during the inspections and have a right to receive a copy of the inspection reports. The operating and reserve budgets of the Association shall take into account the costs of complying with the Maintenance Manual. Changes or updates to the Maintenance Manual should be based upon the advice of competent experts or consultants.

(r) Implement and follow the Hazardous Materials Operations and Maintenance Manual prepared by Connor Solutions.

(s) Elect directors and act as voting representative for Condominium in connection with the Master Association.

3.8 **Managing Agent or Manager.** On behalf of the Association, the board of directors may employ or contract for a managing agent or a manager at a compensation to be established by the board of directors. The board of directors may delegate to the managing agent or manager such duties and powers as the board of directors may authorize. In the absence of such appointment, the board of directors shall act as manager; provided, however, that the board of directors may not terminate professional management and assume self-management unless the decision to do so is approved by at least seventy-five percent (75%) of the total voting rights of the Association.

3.9 **Contracts Entered into by Declarant or Interim Board.** Notwithstanding any other provision of these Bylaws, any management contracts, service contracts or employment contracts entered into by the Declarant or the interim board on behalf of the Association shall have a term not in excess of three years. In addition, any such contract shall provide that it may be terminated without cause or penalty by the Association or board of directors upon not less than thirty (30) days' notice to the other party given not later than sixty (60) days after election of the permanent board at the organizational and turnover meeting described in Section 2.2 of these Bylaws.

3.10 **Organizational Meeting.** Unless otherwise agreed by the board, within fourteen (14) days following the annual meeting of the Association or following any meeting at which an election of directors has been held, the board of directors shall hold an organization meeting at such place and time as shall have been fixed by the directors at the meeting at which the election was held.

3.11 **Regular and Special Meetings.** Regular meetings of the board of directors may be held at such time and place as shall be determined, from time to time, by a majority of the directors. Special meetings of the board of directors may be called by the chairperson and must be called by the secretary at the written request of at least two directors. Notice of any special meeting shall be given to each director, personally or by mail, telephone or telegraph at least seven (7) days prior to the day named for such meeting, and shall state the time, place and purpose of such meeting. For a period of ten (10) years following recording of the Declaration, notices of meetings (including agendas) shall also be given to Declarant in the same manner as given to Directors. Unless other rules of order are adopted by resolution of the Association or the board of directors, all meetings of the board of directors shall be conducted according to the latest edition of *Robert's Rules of Order* published by Robert's Rules Association.

3.12 **Open Meetings.**

(a) All meetings of the board of directors shall be open to unit owners and, for a period of ten (10) years following recording of the Declaration, to Declarant or a representative of Declarant, except that, in the discretion of the board, the following matters may be considered in executive session: (i) consultation with legal counsel concerning the rights and duties of the Association regarding existing or potential litigation, or criminal matters; (ii) personnel matters, including salary negotiations and employee discipline; (iii) negotiation of contracts with third parties; and (iv) collection of unpaid assessments. Except in the case of an emergency, the board of directors shall vote in an open meeting whether to meet in executive session. If the board of directors votes to meet in executive session, the presiding officer shall state the general nature of the action to be considered, as precisely as possible, when and under what circumstances the deliberations can be disclosed to owners. The statement, motion or decision to meet in the executive session shall be included in the minutes of the meeting, and any contract or action considered in executive session shall not become effective unless the board, following the executive session, reconvenes in open meeting and votes on the contract or action, which shall be reasonably identified in the open meeting and included in the minutes.

(b) Meetings of the board of directors may be conducted by telephonic communication or by other means of communication that allows all members of the board participating to hear each other simultaneously or otherwise to be able to communicate during the meeting, except that if a majority of the units are principal residences of the occupants, then: (i) for other than emergency meetings, notice of each board of directors' meeting shall be posted at a place or places on the property at least three (3) days prior to the meeting, or notice shall be provided by a method otherwise reasonably calculated to inform the unit owners of such meeting; and (ii) only emergency meetings of the board of directors may be conducted by telephonic communication or such other means. The meeting and notice requirements of this Section may not be circumvented by chance or social meetings or by any other means.

3.13 **Waiver of Notice.** Any director may, at any time, waive notice of any meeting of the board of directors in writing, and such waiver shall be deemed equivalent to the giving of such notice. Attendance by a director at any meeting of the board shall constitute a waiver of notice by such director, except where the director attends the meeting for the express purpose of objecting to the transaction of any business because the meeting is not lawfully called or convened. If all of the directors are present at any meeting of the board, no notice to directors shall be required and any business may be transacted at such meeting.

3.14 **Quorum of Board of Directors.** At all meetings of the board of directors, a majority of the directors shall constitute a quorum for the transaction of business, and the votes of a majority of the directors present at a meeting at which a quorum is present shall constitute the decision of the board of directors. If at any meeting of the board of directors less than a quorum should be present, a majority of

those present may adjourn the meeting from time to time. At any such adjourned meeting at which a quorum is present, any business that might have been transacted at the meeting originally called may be transacted without further notice to directors.

3.15 **Compensation.** No director shall receive any compensation from the Association for acting as such.

3.16 **Liability and Indemnification of Directors, Officers and Manager.** A member of the board of directors or an officer of the Association shall not be liable to the Association, any unit owner or any third party for any damage, loss or prejudice suffered or claimed on account of any action or failure to act in the performance of his or her duties so long as the individual acted in good faith, believed that the conduct was in the best interests of the Association, or at least was not opposed to its best interests, and in the case of criminal proceedings, had no reason to believe the conduct was unlawful. A director appointed under Section 3.2 of these Bylaws and Section 14.4 of the Declaration, or acting under ORS 100.200, shall not be liable to the Association, any unit owner or any third party under ORS 65.357-65.361, ORS 100.417 or associated rules of common law for any damage, loss or prejudice suffered or claimed on account of any action or failure to act that represents the exercise of authority established in Section 14.4 of the Declaration and ORS 100.200, including any action or failure to act requested by the Declarant or resulting from any prior or concurrent duty or loyalty owed by such director to the Declarant; provided that nothing in this section limits the liability of the Declarant for such actions or failure to act by a director. In the event any member of the board of directors or any officer of the Association is threatened with or made a party to any proceeding because the individual was or is a director or officer of the Association, the Association shall defend such individual against such claims and indemnify such individual against liability and expenses incurred to the maximum extent permitted by law. The manager of the Association, and its officers and employees, shall not be liable to the Association, the unit owners or any third party on account of any action or failure to act in the performance of its duties as manager, except for acts of gross negligence or intentional acts. Prior to the Organizational and Turnover Meeting described in Section 2.2, the manager shall not be liable to the Association, any unit owner or any third party for any damage, loss or prejudice suffered or claimed on account of any action or failure to act that represents the exercise of authority established in Section 14.4 of the Declaration and ORS 100.200, including any action or failure to act requested by the Declarant or resulting from any prior or concurrent duty or loyalty owed by such director to the Declarant; provided that nothing in this section limits the liability of the Declarant for such actions or failure to act by the manager. In the event the manager is threatened with or made a party to any proceeding, the Association shall defend the manager against such claims and indemnify the manager and its officers and employees from any such claims to the maximum extent permitted by law.

3.17 **Insurance.** The board of directors shall obtain the insurance and fidelity bonds required in Article 8 of these Bylaws. In addition, the board of directors, in its discretion, may obtain such other insurance as it deems necessary to protect the interests of the Association or unit owners. The board of directors shall conduct an annual insurance review which, if appropriate, shall include an appraisal of all improvements contained in the Condominium.

#### **Article 4**

#### **OFFICERS**

4.1 **Designation.** The principal officers of the Association shall be the chairperson, the secretary and the treasurer, all of whom shall be elected by the board of directors. The directors may appoint a vice chairperson, an assistant treasurer, an assistant secretary, and such other officers as in their

judgment may be necessary. The chairperson shall be a member of the board of directors, but the other officers need not be directors or unit owners.

4.2 **Election of Officers.** The officers of the Association shall be elected annually by the board of directors at the organization meeting of each new board and shall hold office at the pleasure of the board. If any office shall become vacant, the board of directors shall elect a successor to fill the unexpired term at any regular meeting of the board of directors, or at any special meeting of the board of directors called for such purpose.

4.3 **Removal of Officers.** Upon the affirmative vote of a majority of the directors, any officer may be removed either with or without cause, and a successor may be elected at any regular meeting of the board of directors, or at any special meeting of the board of directors called for such purpose.

4.4 **Chairperson.** The chairperson shall be the chief executive officer of the Association. He or she shall preside at all meetings of the Association and of the board of directors. The chairperson shall have all of the general powers and duties that are usually vested in the chief executive officer of an association, including but not limited to the power to appoint committees from among the unit owners from time to time as the chairperson may in his or her discretion decide is appropriate to assist in the conduct of the affairs of the Association.

4.5 **Secretary.** The secretary shall keep the minutes of all proceedings of the board of directors and the minutes of all meetings of the Association. He or she shall attend to the giving and serving of all notices to the unit owners and directors and other notices required by law. The secretary shall keep the records of the Association, except for those of the treasurer, and shall perform all other duties incident to the office of secretary of an association and as may be required by the directors or the chairperson. In addition, the secretary shall act as vice chairperson, taking the place of the chairperson and performing the chairperson's duties whenever the chairperson is absent or unable to act, unless the directors have appointed another vice chairperson.

4.6 **Treasurer.** The treasurer shall have the responsibility for Association funds and securities and shall be responsible for keeping full and accurate financial records and books of account showing all receipts and disbursements, and for the preparation of required financial statements. He or she shall be responsible for overseeing the deposit of all moneys and other valuable effects in such depositories as may from time to time be designated by the board of directors, and shall disburse or cause to be disbursed funds of the Association upon properly authorized vouchers. The treasurer shall perform all other duties incident to the office of treasurer of an association and such other duties as may be assigned to him or her by the board of directors.

4.7 **Execution of Instruments.** All agreements, contracts, deeds, leases and other instruments of the Association, except checks, shall be executed by such person or persons as may be designated by general or special resolution of the board of directors and, in the absence of any general or special resolution applicable to any such instrument, then such instrument shall be signed by the chairperson. All checks shall be signed by the treasurer, or in the absence or disability of the treasurer, by the chairperson or any duly elected assistant treasurer, or by the manager.

4.8 **Compensation of Officers.** No officer who is a member of the board of directors shall receive any compensation from the Association for acting as an officer, unless such compensation is authorized by a resolution duly adopted by the unit owners. The board of directors may fix any compensation to be paid to any officers who are not also directors.

## Article 5

### **BUDGET, EXPENSES AND ASSESSMENTS**

5.1 **Budget.** The board of directors shall from time to time, and at least annually, prepare a budget for the Association, estimate the common expenses expected to be incurred, less any previous overassessment and plus any underassessment, and assess the common expenses to each unit owner in the proportion set forth in the Declaration. The budget shall provide for a reserve fund in accordance with Section 5.5 below and shall take into account the Maintenance Manual adopted pursuant to Section 3.7(q) above. Within thirty (30) days after adopting the annual budget, the board of directors shall provide a summary of the budget to all owners. If the board of directors fails to adopt an annual budget, the last adopted budget shall continue in effect.

5.2 **Determination of Common Expenses.** Common expenses shall include:

- (a) Expenses of administration, including management fees.
- (b) Expenses of maintenance, repair or replacement of common elements, any other portions of the Condominium required to be maintained by the Association pursuant to the Declaration or these Bylaws, and any Association property.
- (c) Cost of insurance or bonds obtained in accordance with these Bylaws.
- (d) A general operating reserve, including an amount sufficient to cover the deductible under the property damage insurance policy.
- (e) Reserve for replacements, repairs and maintenance.
- (f) Any deficit in common expenses for any prior period.
- (g) Utilities and services for the common elements and other utilities and services with a common meter or commonly billed, such as trash collection, water and sewer.
- (h) Assessments of the Master Association pursuant to the Master Declaration.
- (i) Any other items properly chargeable as an expense of the Association.

5.3 **Assessment of Common Expenses.**

(a) **Obligation to pay.** All unit owners shall be obligated to pay common expenses assessed to them by the board of directors on behalf of the Association pursuant to these Bylaws and the Declaration. No unit owner by the owner's own action may claim exemption from liability for contribution towards common expenses by waiver by the owner of use or enjoyment of any of the common elements or by abandonment by the owner of the owner's unit. A unit owner may not claim an offset against an assessment for failure of the Association to perform its obligations and no unit owner may offset amounts owing or claimed to be owing by the Association or Declarant to the unit owner. Declarant shall be assessed as the unit owner of any unsold unit, but such assessments shall be prorated to the date of sale of the unit. The board of directors, on behalf of the Association shall assess the common expenses against the unit owners from time to time, and at least annually, and shall take prompt action to collect from a unit owner any common expense due that remains unpaid for more than thirty (30) days from the due date for its payment. The board may elect to round assessments to the nearest dollar.

(b) **Working capital fund.** At the time of closing of the initial sale of each unit to a person other than a successor declarant and thereafter on any subsequent sale of a unit, the purchaser shall make a contribution to the working capital of the Association equal to two (2) months' regular association assessments for the unit, which sums shall be held in a segregated working capital fund established in the name of the Association. At the time of the organizational and turnover meeting, the Declarant shall pay such contribution for all unsold units, but may obtain reimbursement for such sums from the purchaser upon the sale of each such unit. Such contribution shall be in addition to the regular monthly common expense assessment and shall not be considered as an advance payment of regular assessments. The working capital fund shall be held by the Association for deposit into the reserve account described in Section 5.5 below at the time of the organizational and turnover meeting. Declarant may not use the working capital fund to defray any of Declarant's expenses, reserve contributions, or construction costs or to make up any budget deficits while Declarant is in control of the Association.

(c) **Commencement of regular operating expense assessments.** Regular monthly assessments for common operating expenses shall commence upon closing of the first sale of a unit in the Condominium. Declarant may elect to defer commencement of common operating expense assessments as to all units until the earlier of (i) the sale of 25% of the Living Units in the Condominium have closed, or (ii) the turnover meeting described in Section 2.2 above. If Declarant so elects to defer commencement of assessments for operating expenses, Declarant shall pay and be responsible for all common operating expenses as they accrue, without cost or operating expense assessment to the other unit owners, until regular operating expense assessments commence. Declarant shall give 10 days' written notice to individual unit owners prior to the commencement of regular operating expense assessments.

(d) **Commencement of assessment for replacement reserves.** Regular monthly assessments for replacement reserves as described in Section 5.5 for all units in the Condominium shall commence upon the closing of the sale of the first unit in the Condominium. Declarant may elect to defer payment of such reserve assessments to the Association for each unit owned by Declarant until the closing of the sale of such unit, but not beyond the date of the turnover meeting referred to in Section 2.2 above, or if no turnover meeting is held, the date the owners assume administrative control of the Association. The books and records of the Association shall reflect the amount owing from Declarant for all reserve assessments.

#### 5.4 **Special or Extraordinary Assessments.**

(a) **Special Assessments for Capital Improvements.** In the case of any duly authorized capital improvement to the common elements, the board of directors may by resolution establish separate assessments for the same, which may be treated as capital contributions by the unit owners, and the proceeds of which shall be used only for the specific capital improvements described in the resolution. The Association shall not assess units owned by the Declarant for additional capital improvements to the Condominium without the written consent of Declarant as long as Declarant owns more than five percent (5%) of the units submitted to the Condominium.

(b) **Other Special or Extraordinary Assessments.** In the event the board of directors determines that the assessments established upon adoption of the budget as provided in Section 5.1 above will be insufficient to pay the common expenses, or the board of directors determines that additional funds will be needed to meet unexpected or unbudgeted common expenses, the board may levy an additional special or extraordinary assessment. Such assessment shall be allocated to each unit in the same proportion set forth in the Declaration, and may be payable in installments over a specified period, in a lump sum, or in a lump sum with option to pay in installments with interest, as determined by the board of directors.

## 5.5 **Replacement Reserves.**

(a) **Establishment of Account.** The Declarant shall conduct a reserve study as described in paragraph (c) of this Section and establish a reserve account for replacement of those common elements all or a part of which will normally require replacement in more than three (3) and less than thirty (30) years, for significant future maintenance items as required by the Maintenance Manual established pursuant to Section 3.7(q) and for exterior painting if the common elements include exterior painted surfaces. The reserve account need not include those items that could reasonably be funded from operating assessments.

(b) **Funding of Account.** The reserve account shall be funded by assessments against the individual units for the purposes for which the reserve account is being established, which sums shall be included in the regular monthly assessment for the unit, except as otherwise provided in Section 5.3(b). The reserve account shall be established in the name of the Association.

(c) **Reserve Studies.** The board of directors annually shall conduct a reserve study or review and update an existing study to determine the reserve account requirements for the items described in paragraph (a) of this Section and may adjust the amount of payments in accordance with the study or review and may provide for other reserve items that the board of directors, in its discretion, may deem appropriate. The reserve account need not include items that could reasonably be funded from operating assessments. The reserve study shall include:

- (1) Identification of all items for which reserves are to be established;
- (2) The estimated remaining useful life of each item as of the date of the reserve study;
- (3) An estimated cost of maintenance, repair or replacement of each item at the end of its useful life;
- (4) An update of the Maintenance Manual based upon the advice of competent experts or consultants; and
- (5) A thirty (30) year plan for the maintenance, repair and replacement of common elements and Association property with regular and adequate contributions, adjusted by estimated inflation and interest earned on reserves, to meet the maintenance, repair and replacement schedule.

The board of directors shall, within 30 days after conducting the reserve study, provide to every unit owner a written summary of the reserve study and of any revisions to the 30-year plan adopted by the board of directors or the Declarant as a result of the reserve study.

(d) **Use of Reserve Funds.** The reserve account shall be used only for the purposes for which the reserves have been established and shall be kept separate from other funds. After the organizational and turnover meeting described in Section 2.2, however, the board of directors may borrow funds from the reserve account to meet high seasonal demands on the regular operating funds or to meet unexpected increases in expenses if the board of directors has adopted a resolution, which may be an annual continuing resolution, authorizing the borrowing of funds. Not later than the adoption of the budget for the following year, the board of directors shall adopt by resolution a written payment plan providing for repayment of the borrowed funds within a reasonable period. In addition to the authority of the board of directors under paragraph (c) of this Section, after the organizational and turnover meeting,



the Association may, on an annual basis, elect not to fund the reserve account described in paragraph (a) of this Section by unanimous vote of the owners or elect to reduce or increase future assessments for the reserve account by an affirmative vote of at least seventy-five percent (75%) of the voting rights.

(e) **Sale of Units.** Nothing in this Section shall prohibit prudent investment of the reserve account. Assessments paid into the reserve account are the property of the Association and are not refundable to sellers of units. Sellers of the units, however, may treat their outstanding share of the reserve account as a separate item in any sales agreement.

5.6 **Default in Payment of Assessments.** In the event of default by any unit owner in paying any assessments to the Association, including assessed common expenses and any other charge imposed or levied by the Association pursuant to the provisions of the Declaration, these Bylaws or the Oregon Condominium Act, such unit owner shall be obligated to pay interest at the rate of twelve percent (12%) per annum on such assessment from the due date thereof, or at such greater rate as may be established by the board of directors from time to time, not to exceed the maximum lawful rate, if any. In addition, the defaulting unit owner shall pay a late charge for any assessment not paid within ten (10) days of its due date in the amount of five percent (5%) of the delinquent payment, or such other reasonable late charge or administrative fee, or both, as may be established by the board of directors from time to time by resolution that is delivered to each unit, mailed to the mailing address of each unit or mailed to the mailing address designated by the unit owner in writing, together with all expenses incurred by the Association in collecting such unpaid assessments, including attorneys' fees (whether or not suit is instituted, and at trial or any appeal or petition for review therefrom). If the assessment is not paid within thirty (30) days of its due date, the board of directors may declare any remaining installments of assessments for the balance of the fiscal year immediately due and payable and may terminate the right to receive utility services paid for out of assessments or the right of access to and use of recreational and service facilities of the Condominium until assessments have been brought current. The board of directors shall have the right and duty to recover for the Association such assessments, together with such charges, interest and expense of the proceeding, including attorneys' fees, by an action brought against such unit owner or by foreclosure of the lien upon the unit granted by the Oregon Condominium Act. The board of directors shall notify the holder of any first Mortgage upon a unit of any default not cured within sixty (60) days of the date of default.

5.7 **Foreclosure of Liens for Unpaid Assessments.** In any suit brought by the Association to foreclose a lien on a unit because of unpaid assessments, the unit owner shall be required to pay a reasonable rental for the use of the unit during the pendency of the suit, and the plaintiff in such foreclosure suit shall be entitled to the appointment of a receiver to collect such rental. The board of directors, acting on behalf of the Association, shall have the power to purchase such unit at the foreclosure sale and to acquire, hold, lease, Mortgage, vote the votes appurtenant to, convey, or otherwise deal with the unit. A suit or action to recover a money judgment for unpaid assessments shall be maintainable without foreclosing the liens securing the same.

5.8 **Statement of Assessments.** The board of directors shall advise each unit owner in writing of the amount of assessments payable by such owner, and furnish copies of each budget on which such assessments are based to all unit owners and, if requested, to their Mortgagees. The board of directors shall promptly provide any unit owner who makes a request in writing with a written statement of the owner's unpaid assessments.

5.9 **Priority of Lien; First Mortgages.** To the extent provided by the Oregon Condominium Act, any lien of the Association against a unit for assessments shall be subordinate to tax and assessment liens and any first Mortgage of record. Unless otherwise provided in the Oregon Condominium Act, where the purchaser or Mortgagee of a unit obtains title to the unit as a result of foreclosure of a first

Mortgage, such purchaser or Mortgagee, its successors and assigns, shall only be liable for a maximum of six (6) months of the assessments chargeable to such unit that became due prior to the acquisition of title to such unit by such purchaser or Mortgagee. Any additional unpaid share of assessments shall be a common expense and reallocated on a pro rata basis for all units, including the Mortgaged unit. The purchaser or Mortgagee shall not be relieved of the obligation to pay further assessments. A deed in lieu of foreclosure accepted by the holder of a first Mortgage shall extinguish a lien filed by the Association to secure unpaid assessments under the circumstances described in ORS 100.465.

5.10 **Voluntary Conveyance.** In a voluntary conveyance of a unit, the grantee shall be jointly and severally liable with the grantor for all unpaid assessments against the grantor of the unit up to the time of the grant or conveyance, without prejudice to the grantee's right to recover from the grantor the amounts paid by the grantee therefor. However, upon request of an owner or an owner's agent, for the benefit of a prospective purchaser, the board of directors shall make and deliver a statement of the unpaid assessments against the prospective grantor or the unit effective through a date specified in the statement, and the grantee in that case shall not be liable for any unpaid assessments against the grantor not included in the written statement.

## Article 6

### **RECORDS AND AUDITS**

6.1 **General Records.** The board of directors and the manager, if any, shall keep detailed records of the actions of the board of directors and the manager, minutes of the meetings of the board of directors and minutes of the meetings of the Association. The board of directors shall maintain a Book of Resolutions containing the rules, regulations and policies adopted by the Association, board of directors and the manager. The board of directors shall maintain a list of owners entitled to vote at meetings of the Association and a list of all Mortgagees of units. All documents, information and records delivered to the Association by the Declarant pursuant to ORS 100.210 and other records of the Association shall be kept within the State of Oregon for the time periods specified in ORS 100.480.

6.2 **Financial Records and Accounts.** The board of directors or its designee shall keep within the State of Oregon financial records sufficient for proper accounting purposes and as required by the Oregon Condominium Act. All assessments shall be deposited in a separate bank account, located in the State of Oregon, in the name of the Association. All expenses of the Association shall be paid from the Association's bank account.

6.3 **Assessment Roll.** The assessment roll shall be maintained in a set of accounting books in which there shall be an account for each unit. Such account shall designate the name and address of the owner or owners, the amount of each assessment against the owners, the dates and amounts in which the assessment comes due, the amounts paid upon the account and the balance due on the assessments.

6.4 **Payment of Vouchers.** The treasurer or manager shall pay all vouchers for all budgeted items and for any nonbudgeted items up to \$1,000 signed by the chairperson, managing agent, manager or other person authorized by the board of directors. Any voucher for nonbudgeted items in excess of \$1,000 shall require the authorization of the chairperson. Any checks written on reserve accounts must be signed by a member of the board of directors.

6.5 **Reports and Audits.** An annual financial statement consisting of a balance sheet and income and expense statement for the preceding fiscal year shall be rendered by the board of directors to all unit owners and to all Mortgagees of units who have requested the same within ninety (90) days after the end of each fiscal year. Commencing with the fiscal year following the Turnover Meeting, if the

annual assessments exceed \$75,000 for the year, then the Board of Directors shall cause such financial statements to be reviewed within one hundred eighty (180) days after the end of the fiscal year by an independent certified public accountant licensed in Oregon in accordance with the Statements on Standards for Accounting and Review Services issued by the American Institute of Certified Public Accountants, or if the annual assessments are \$75,000 or less, shall cause such review within 180 days after receipt of a petition requesting such review signed by owners holding at least a majority of the voting rights. The board of directors need not cause such a review to be performed if so directed by an affirmative vote of unit owners holding at least sixty percent (60%) of the voting rights, not including votes of Declarant with respect to units owned by Declarant. Upon written request, any holder, insurer or guarantor of a first Mortgage shall be entitled to an audited financial statement for the immediately preceding fiscal year at the expense of the requesting party, if one is not otherwise available.

6.6 **Notice of Sale, Mortgage, Rental or Lease.** Upon the sale, mortgage, rental or lease of any unit, such unit owner shall promptly inform the secretary or manager of the name and address of the vendee, Mortgagee, lessee, or tenant.

6.7 **Availability of Records.** Except as otherwise provided in ORS 100.480(5)(b), during normal business hours or under other reasonable circumstances, the Association shall make reasonably available for examination and, upon written request, available for duplication, by unit owners, lenders and holders, insurers, or guarantors of any first Mortgage that make the request in good faith for a proper purpose, current copies of the Declaration, bylaws, other rules concerning the Condominium, amendments or supplements to such documents, and the books, records, financial statements and current operating budget of the Association. The Association, within ten (10) business days after receipt of a written request by a unit owner, shall furnish copies of such documents to the requesting unit owner. Upon written request, the Association shall make such documents, information and records available to such persons for duplication during reasonable hours. The board of directors, by resolution, may adopt reasonable rules governing the frequency, time, location, notice and manner of examination and duplication of Association records and the imposition of a reasonable fee for furnishing copies of such documents, information or records. The fee may include reasonable personnel costs incurred to furnish the information.

6.8 **Statement of Assessments Due.** The Association shall provide, within ten (10) business days of receipt of a written request from an owner, a written statement that provides: (a) the amount of assessments due from the owner and unpaid at the time the request was received, including regular and special assessments, fines and other charges, accrued interest, and late payment charges; (b) the percentage rate at which interest accrues on assessments that are not paid when due; and (c) the percentage rate used to calculate the charges for late payment or the amount of a fixed rate charge for late payment. The Association is not required to comply with this Section if the Association has commenced litigation by filing a complaint against the owner and the litigation is pending when the statement would otherwise be due.

## Article 7

### **MAINTENANCE AND USE OF CONDOMINIUM PROPERTY**

7.1 **Maintenance and Repair.** Except as otherwise provided in Section 7.3 for damage or destruction caused by casualty:

(a) **Units.** All maintenance of and repairs to any unit shall be made by the owner of such unit, who shall keep the same in good order, condition and repair and shall do all redecorating, painting and staining that at any time may be necessary to maintain the good appearance and condition of

the unit. In addition, each unit owner shall be responsible for the maintenance, repair, or replacement of windows and doors, any plumbing, heating or air conditioning fixtures, telephones, water heaters, fans, vents, lighting fixtures and lamps, electrical outlets, blinds, garbage disposals, fireplaces, refrigerators, dishwashers, ranges, or other appliances and accessories that may be in or connected with such owner's unit. The Association, however, may repair or replace, at the Association's expense, portions of units to the extent reasonably necessary for the preservation of the common elements in good condition and working order. The Association, however, shall be responsible for exterior window washing.

(b) **Common elements.** All maintenance, repairs and replacements to the general and limited common elements and to Association property shall be made by the Association and shall be charged to all the unit owners as a common expense. Each unit owner, however, shall keep the limited common elements that pertain to such owner's unit in a safe, neat, clean and sanitary condition. The common elements shall be maintained in accordance with the requirements of the Master Declaration.

## 7.2 **Additions, Alterations or Improvements.**

(a) A unit owner may not make any improvements or alterations to such owner's unit without first notifying the Association and obtaining approval by the board of directors of the proposed alteration. The owner shall have the burden of establishing, to the reasonable satisfaction of the board of directors, that the proposed improvements or alterations will not impair the structural integrity or mechanical systems of the Condominium, lessen the support of any portion of the Condominium, jeopardize the soundness or safety of the Condominium, reduce its value, impair any easement or hereditament, increase the common expenses or increase sound transmissions to other units. The board of directors may elect to require contractors to coordinate their access and working hours so as to minimize disruption to the Condominium. A unit owner shall reimburse the Association for any actual costs incurred by the Association in reviewing and monitoring such alterations.

(b) After acquiring an adjoining unit or an adjoining part of an adjoining unit, a unit owner may submit a written request to the board of directors for permission to remove or alter any intervening partition or to create apertures therein, even if the partition in whole or in part is a common element. The board of directors shall approve the change unless it determines within forty-five (45) days that the proposed change will impair the structural integrity or mechanical systems of the Condominium or lessen the support of any portion of the Condominium. The board of directors may require the unit owner, at such owner's own expense, to submit an opinion of a registered architect or registered professional engineer that the proposed change will not impair the structural integrity or mechanical systems of the Condominium or lessen the support of any portion of the Condominium. Removal of partitions or creation of apertures under this paragraph is not an alteration of boundaries.

(c) A unit owner may not change the appearance of the common elements or the exterior appearance of a unit without the prior written permission of the board of directors. No person shall install wiring for electrical or telephone installation, television antennas or satellite dishes, machines or air conditioning units, or similar devices on the exterior of the Condominium or cause them to protrude through the walls or the roof of the Condominium except as authorized by the board of directors. No exterior window guards, awnings, or shades shall be installed without prior consent of the board of directors.

(d) No additional plumbing fixtures may be added to the existing plumbing system. Accordingly, washers may not be added to units that do not already have washer hookups.

**7.3 Damage or Destruction by Casualty of Condominium Property.** In the case of damage or destruction that affects a material portion of the Condominium, timely written notice shall be given to the unit owners and their Mortgagees and the following provisions shall apply:

(a) In the event of damage or destruction by casualty of Condominium property, the damage or destruction shall be repaired, reconstructed or rebuilt unless, within fourteen (14) days of such damage or destruction, the board of directors or unit owners holding more than ten percent (10%) of the voting rights shall have requested a special meeting of the Association. Such special meeting must be held within sixty (60) days of the date of damage or destruction. At the time of such meeting, unless unit owners holding ninety percent (90%) of the voting rights, whether in person, by writing or by proxy, with the approval of Mortgagees as required by the Declaration, vote not to repair, reconstruct or rebuild the damaged property, the damage or destruction shall be repaired, reconstructed or rebuilt. If the damage or destruction is not repaired, reconstructed or rebuilt, then the property shall be removed from condominium ownership in the manner provided in the Oregon Condominium Act.

(b) The Association shall be responsible for repairing, reconstructing or rebuilding all such damage or destruction to the common elements and, to the extent of the Association's insurance coverage, all such damage or destruction to the units. Each unit owner shall be responsible for the cost of such repairing, reconstructing or rebuilding of his or her unit as is not so covered by the Association's insurance and to the extent of any deductible under the Association's insurance.

(c) If, due to the act or neglect of a unit owner, or of a member of such owner's family or household pet or of a guest or other occupant or visitor of such unit owner, damage shall be caused to the common elements or to a unit owned by others, or maintenance, repairs or replacements shall be required that would otherwise be a common expense, then such unit owner shall pay for such damage and such maintenance, repairs and replacements as may be determined by the Association, to the extent not fully covered by the Association's insurance.

(d) In the event any portion of the insurance proceeds paid to the Association is not used to repair, reconstruct or rebuild the damaged or destroyed property, the Association shall distribute the proceeds among the unit owners and their Mortgagees (as their interests may appear) in the same proportion as common expenses are shared, unless the property is removed from unit ownership. If the property is removed from unit ownership, the insurance proceeds, together with the proceeds from the sale of the property, shall be distributed to the unit owners and their Mortgagees (as their interests may appear) in the manner described in the Oregon Condominium Act.

**7.4 Condemnation.** If any portion of the Condominium is made the subject matter of any condemnation or eminent domain proceeding or is otherwise sought to be acquired by a condemning authority, notice of the proceeding or proposed acquisition shall promptly be given to each unit owner and to each Mortgagee. The Association shall represent the unit owners in any condemnation proceedings or in negotiations, settlements and agreements with the condemning authority for acquisition of any portion of the common elements, and each unit owner appoints the Association to act as his attorney-in-fact for such purposes. All compensation, damages or other proceeds of the taking, other than any award for moving expenses of specific unit owners, shall be payable to the Association and allocated and distributed as provided in this Section 7.4.

(a) **Complete Taking.** If the entire Condominium property is taken, or if unit owners holding ninety percent (90%) of the voting rights agree that such substantial portion of the Condominium has been taken as to make the project obsolete, then the property shall be deemed removed from unit ownership. In such event, any proceeds of the condemnation paid to the Association, together with any other proceeds upon sale of the remaining Condominium property, shall be distributed among

the unit owners and their Mortgagees, as their interests may appear, in accordance with the provisions of the Oregon Condominium Act.

(b) **Partial Taking.** If less than the entire Condominium property is taken and the property is not determined to be obsolete as provided in paragraph (a) above, then as soon as practicable the board of directors shall, reasonably and in good faith, allocate the award among the units in accordance with the reduction in the value of each unit and its interest in the common elements, compared to the total reduction in value of all units and their interest in the common elements. In the event any unit owner or Mortgagee objects to the allocation determined by the board of directors, the matter shall be submitted to arbitration in accordance with Article 10 below. The cost of such determination shall be paid out of the proceeds of the condemnation. Any portion of the award allocated to a unit owner under this paragraph shall be paid first to all Mortgagees and holders of liens on the unit owner's interest in accordance with the existing priorities, and the balance to the unit owner. If any reconstruction or repair is undertaken as a result of the condemnation, the board of directors may retain and apply such portion of each unit owner's share of the award as is necessary to discharge the owner's liability for any special assessment arising from such reconstruction or repair.

7.5 **Restrictions and Requirements Respecting Use of Condominium Property.** The following restrictions and requirements are in addition to all other restrictions and requirements contained in the Declaration and these Bylaws:

(a) **Residential use.** No commercial activities of any kind shall be carried on in any Living Unit or in any other portion of the Condominium without the consent of the board of directors of the Association, except activities relating to the rental or sale of units. This provision, however, shall not be construed so as to prevent or prohibit a unit owner from maintaining his or her professional personal library, keeping his or her personal business or professional records or accounts, handling his or her personal business or professional telephone calls, or conferring with business or professional associates, clients or customers, in such owner's unit.

(b) **Use of common elements.** The common elements shall be used for the furnishing of services and facilities for which the same are reasonably intended, for the enjoyment of the units. The use, operation and maintenance of the common elements shall not be obstructed, damaged or unreasonably interfered with by any unit owner.

(c) **Offensive or unlawful activities.** No noxious or offensive activities shall be carried on in any unit nor shall anything be done in or placed upon any unit or common element that interferes with or jeopardizes the enjoyment of other units or the common elements or which is a source of annoyance to residents. Unit occupants shall exercise extreme care not to make noises that may disturb other unit occupants, including the use of musical instruments, radios, televisions and amplifiers. Speakers for audio equipment may not be mounted on or against walls or floors without an adequate sound barrier to prevent vibration and transmission of bass sounds outside of the unit. Occupants may not discard or throw items out of windows or from decks, including, without limitation cigarettes or ashes. No unlawful use shall be made of the Condominium nor any part thereof, and all valid laws, zoning ordinances, and regulations of all governmental bodies having jurisdiction thereof shall be observed. Owners and other occupants shall not engage in any abusive or harassing behavior, either verbal or physical, or any form of intimidation or aggression directed at other owners, occupants, guests, or invitees, or directed at the manager, its agents or employees, or vendors.

(d) **Animals.** No animals or fowls shall be raised, kept or permitted within the Condominium or any part thereof, except domestic dogs, cats, and other ordinary household pets kept within a unit. No such dogs shall be permitted to run at large, nor shall any dogs, cats or pets be kept,

bred or raised for commercial purposes or in unreasonable numbers. Any inconvenience, damage or unpleasantness caused by such pets shall be the responsibility of the respective owners thereof, and owners shall be responsible for clean up and removal of wastes of their animals. No Rotweillers, Pit Bulls or Canary Island dogs are permitted within the Condominium. All pets shall be kept under reasonable control at all times and shall be carried or kept on a leash while outside a unit. Each Owner and occupant shall be responsible for seeing that his or her pets do not endanger health, make objectionable noise, or constitute a nuisance or inconvenience to the Owners and occupants of other units. The board of directors, after notice and a hearing, may require the permanent removal of any animal that the board determines to be a danger to the health and safety of any occupant in the Condominium, or otherwise to be a nuisance within the Condominium. The board may find that an animal is a nuisance if the animal or its owner continue to violate these Bylaws or the rules regulating pets after receipt by the Owner of a written demand from the board to comply with these Bylaws or the rules.

(e) **Exterior lighting or noisemaking devices and antennas.** Except with the consent of the board of directors of the Association, no exterior lighting or noisemaking devices shall be installed or maintained on any unit. Seasonal holiday lighting and decorations are permissible if consistent with any applicable rules and regulations and if removed within thirty (30) days after the celebrated holiday. Exterior antennas, satellite receiver and transmission dishes and other communication devices shall not be permitted to be placed upon the general common elements, and may not be placed on any unit or limited common element except in accordance with rules established by the board of directors.

(f) **Windows, decks, patios and outside walls.** In order to preserve the attractive appearance of the Condominium and regulate load limits, the board of directors of the Association may adopt rules regulating the nature of items that may be placed in or on windows, decks, patios, and the outside walls so as to be visible from other units, the common elements, or outside the Condominium. Garments, rugs, laundry, sheets, reflective surfaces and other similar items may not be hung from windows, facades, patios or decks.

(g) **Signs.** Unless written approval is first obtained from the board of directors, no sign of any kind shall be displayed to the public view on or from any unit or the common elements except signs used by the Declarant to advertise units for sale or lease.

(h) **Trash.** No part of any unit or any part of the common elements shall be used or maintained as a dumping ground for rubbish, trash, garbage, recycling materials or other waste. No garbage, trash, recycling materials or other waste shall be kept or maintained on any part of the property, except in sanitary containers in the designated areas.

(i) **Insurance.** Nothing shall be done or kept in any unit or in the common elements that will increase the cost of insurance on the common elements. No owner shall permit anything to be done or kept in his or her unit or in the common elements that will result in cancellation of insurance on any unit or any part of the common elements.

(j) **Water beds.** Water beds may not be placed in any unit, except with the prior consent of the board of directors. If such consent is given, the unit owner shall carry insurance covering damage caused by the water bed and shall be responsible for all damages to any unit or the common elements that might be caused by the water bed.

(k) **Washing Machines.** Penthouse and Townhome Units contain a washing machine hookup. The unit owner shall be responsible for all damages to any unit or the common elements that might be caused by the washing machine or leakage from the washing machine.

(l) **Parking of Vehicles.** Except with the consent of the board of directors of the Association, no vehicle in an extreme state of disrepair, trailer, truck camper, motorcycle, boat or boat trailer, or other recreational vehicle or truck rated as one ton or more shall be parked on any portion of the Condominium. A vehicle shall be deemed in an "extreme state of disrepair" when the board of directors reasonably determines that its presence offends the occupants of the Condominium due to its appearance or continued inoperability. Working on, repairing or washing of vehicles within the Condominium is prohibited.

(m) **Association rules and regulations.** In addition, the board of directors from time to time may adopt, modify, or revoke such rules and regulations governing the conduct of persons and the operation and use of the units and common elements as it may deem necessary or appropriate in order to assure the peaceful and orderly use and enjoyment of the Condominium property, including, without limitation, establishment of reasonable administrative fees, such as fees for new owner set-up and owner's packet, move-in and move-out fees, etc. Any action by the board of directors adopting, modifying or revoking any rule or regulation may be overruled by a vote of not less than seventy-five percent (75%) of the voting rights present, in person or by proxy, at any meeting, the notice of which shall have stated that such adoption, modification or revocation of rules and regulations will be under consideration. A copy of the rules and regulations, upon adoption, and a copy of each amendment, modification or revocation thereof, shall be delivered by the secretary promptly to each unit owner and shall be binding upon all unit owners and occupants of all units from the date of delivery.

#### 7.6 **Leasing and Rental of Units.**

(a) Any owner who wishes to lease or rent his or her unit must meet each of the following requirements, and the lease or rental agreement will be subject to these requirements whether or not they are included within the lease or rental agreement:

- (1) all leases and rentals must be in writing;
- (2) the unit may not be rented for transient or hotel purposes, and all leases and rentals shall be for a term of not less than thirty (30) days;
- (3) the lease or rental must be for the entire unit and not merely parts of the unit, unless the owner remains in occupancy;
- (4) all such leases and rentals shall be subject in all respects to provisions of the Declaration, these Bylaws, and all rules and regulations adopted by the Board;
- (5) all owners who lease or rent their units shall promptly notify the Association in writing of the names of all tenants and members of tenants' family occupying such units and shall provide the Association with a complete copy of the lease or rental agreement. All owners leasing their unit shall promptly notify the Association of the address and telephone number where such owner can be reached.

(b) Any failure of a tenant to comply with the Declaration, Bylaws, and Association rules and regulations, shall be a default under the lease or rental agreement, regardless of whether the lease or rental agreement so provides. In the event of any such default, the owner immediately shall take all actions to cure the default including, if necessary, eviction of the tenant.

(c) If any tenant is in violation of the provisions of the Declaration, Bylaws, or rules and regulations of the Association, the Association may bring an action in its own name and/or in the



name of the owner to have the tenant evicted and/or to recover damages. If the court finds that the tenant is violating, or has violated any of the provisions of the Declaration, these Bylaws, or the rules and regulations of the Association, the court may find the tenant guilty of unlawful detainer notwithstanding the fact that the owner is not the plaintiff in the action and/or the tenant is not otherwise in violation of tenant's lease. The remedy provided by this subsection is not exclusive and is in addition to any other remedy or remedies which the Association may have. If permitted by present or future law, the Association may recover all its costs, including court costs and reasonable attorneys' fees incurred in prosecuting the unlawful detainer action.

(d) The Association shall give the tenant and the owner notice in writing of the nature of the violation, and twenty (20) days from the mailing of the notice in which to cure the violation before the Association may file for eviction.

(e) Each owner shall provide a copy of the Declaration, these Bylaws and all rules and regulations of the Association to each tenant of his or her unit. By becoming a tenant, each tenant agrees to be bound by the Declaration, these Bylaws and the rules and regulations of the Association, and recognizes and accepts the right and power of the Association to evict a tenant for any violation by the tenant of the Declaration, these Bylaws, and rules and regulations of the Association.

**7.7 Failure to Follow Maintenance Manual.** The Association shall perform all inspections and maintenance as recommended by the Maintenance Manual described in Section 3.7(q) above and make such repairs and maintenance as may be necessary to reasonably address the results of the inspections. If the Association fails to follow such maintenance and inspection requirements, then neither the Association nor any unit owner shall have any claim against Declarant or its design professionals, contractors and subcontractors and their consultants, including without limitation, all of their officers, members, directors, employees, agents, brokers and affiliates, for loss or damage to the extent the same results from such failure to follow the Maintenance Manual, and shall indemnify such persons and entities from and against claims by unit owners or other persons or entities for loss or damage resulting from such failure.

**7.8 Abatement and Enjoining of Violations.** The violation of any provision of the Declaration or these Bylaws, of any rule or regulation adopted pursuant to these Bylaws, or of any decision of the Association made pursuant to such documents, shall give the board of directors, acting on behalf of the Association, the right, in addition to any other rights set forth in these Bylaws, to do any or all of the following after giving written notice and an opportunity to be heard:

(a) to summarily abate and remove, at the expense of the defaulting unit owner, any structure, thing, or condition that may exist contrary to the intent and meaning of such provisions, and the board of directors shall not thereby be deemed guilty of any manner of trespass, provided, however, that judicial proceedings shall be instituted before any items of construction may be altered or demolished; or

(b) to enjoin, abate, or remedy such thing or condition by appropriate legal proceedings; or

(c) to levy reasonable fines based upon a resolution adopted by the board of directors that is delivered to each unit, mailed to the mailing address of each unit or mailed to the mailing address designated by the owner of each unit in writing; or

(d) to terminate the right to receive utility services paid for out of assessments or the right of access to and use of recreational and service facilities of the Condominium until the correction of the violation has occurred.

The offending unit owner shall be liable to the Association for a reasonable administrative fee as established by the board of directors and all costs and attorneys' fees incurred by the Association, whether or not legal proceedings are instituted and including attorneys' fees at trial, in arbitration or on appeal or petition for review, together with any expense incurred by the Association in remedying the default, damage incurred by the Association or unit owners, or fines so levied. Such sums shall be assessed against the offending unit as an assessment and enforced as provided in Article 5. In addition, any aggrieved unit owner may bring an action against such other unit owner or the Association to recover damages or to enjoin, abate, or remedy such thing or condition by appropriate legal proceedings.

## **Article 8**

### **INSURANCE**

8.1 **Types of Insurance.** For the benefit of the Association and the unit owners, the board of directors shall obtain and maintain at all times, and shall pay for out of the common expense funds, the following insurance:

(a) **Property Damage Insurance.**

(1) The Association shall maintain a policy or policies of insurance covering loss or damage from fire, with standard extended coverage and "all risk" endorsements, and such other coverages as the Association may deem desirable.

(2) The amount of the coverage shall be for not less than one hundred percent (100%) of the current replacement cost of the units and common elements (exclusive of land, foundation, excavation and other items normally excluded from coverage), subject to a maximum deductible of the lesser of \$10,000 or one percent (1%) of the policy amount.

(3) The policy or policies shall include all fixtures and building service equipment to the extent that they are part of the common elements and all personal property and supplies belonging to the Association, together with all fixtures, improvements and alterations comprising a part of each unit.

(4) Such policy or policies shall name the Association as insured, and shall provide for loss payable in favor of the Association, as a trustee for each unit owner and each such unit owner's Mortgagee, as their interests may appear. The policies shall contain the standard mortgage clause, or equivalent endorsement (without contribution) that is commonly accepted by institutional mortgage investors in Oregon.

(b) **Liability Insurance.**

(1) The Association shall maintain comprehensive general liability insurance coverage insuring the Declarant, the Association, the board of directors, the unit owners and the manager, against liability to the public or to the owners of units and of common elements, and their invitees or tenants, incident to the operation, maintenance, ownership or use of the property, including legal liability arising out of lawsuits related to employment contracts of the Association. There may be excluded from such policy or policies coverage of a unit owner (other than as a member of the Association or board of directors) for liability arising out of acts or omission of such unit owner and liability incident to the ownership and/or use of the part of the property as to which such unit owner has the exclusive use or occupancy.

(2) Limits of liability under such insurance shall not be less than One Million Dollars (\$1,000,000) on a combined single limit basis.

(3) Such policy or policies shall be issued on a comprehensive liability basis and shall provide a cross liability endorsement wherein the rights of named insured under the policy or policies shall not be prejudiced as respects his, her or their action against another named insured.

(c) **Workers' Compensation Insurance.** The Association shall maintain workers' compensation insurance to the extent necessary to comply with any applicable laws.

(d) **Fidelity Insurance.**

(1) The Association shall maintain fidelity insurance for all officers, directors, trustees and employees of the Association and all other persons handling or responsible for funds of or administered by the Association. In the event the Association has retained a manager, such manager shall maintain fidelity insurance for its officers, employees and agents handling or responsible for funds of, or administered on behalf of, the Association. The cost of such insurance shall be at the expense of the Association.

(2) The total amount of fidelity insurance coverage required shall be based upon the best business judgment of the board of directors. In no event, however, may the aggregate amount of such insurance be less than the sum equal to three months' aggregate assessments on all units plus reserve funds.

(3) Such fidelity insurance shall name the Association as obligee and shall contain waivers by the issuers of the insurance of all defenses based upon the exclusion of persons serving without compensation from the definition of "employees" or similar terms or expressions. The insurance shall provide that it may not be canceled or substantially modified (including cancellation for nonpayment of premium) without at least ten (10) days' prior written notice to the Association and each servicer on behalf of the Federal National Mortgage Association ("FannieMae").

(e) **Directors' and Officers' Liability Insurance.** The Association shall maintain a policy of directors' and officers' liability insurance with coverage in the amount of not less than One Million Dollars (\$1,000,000), subject to a reasonable deductible.

(f) **Insurance by Unit Owners.** The Association has no responsibility to procure or assist in procuring property loss insurance for any owner or tenant for (i) damage to a unit or limited common elements not covered by the Association's policy (because of the deductible amount or because the claim for loss or damage is one not covered by fire and property loss insurance policies required by these Bylaws or held by the Association); or (ii) for any damage or loss to the owner's or tenant's personal property. Owners must be responsible for purchasing insurance policies insuring their units and appurtenant limited common elements for the deductible amount under the Association's policies and for insuring their own personal property for any loss or damage. Proof of such insurance coverage must be provided to the Association by the unit owner. Tenants must be responsible for insuring their own personal property for any loss or damage. The Association shall notify all owners of the amount of the deductible under the Association policies. To the extent reasonably practicable, the Association shall give at least thirty (30) days' notice to the owners of any increase in the deductible proposed in renewal or replacement insurance policies. Owners and tenants of all units must procure and maintain comprehensive liability policies having combined limits in amounts reasonably set by the board of directors no more often than every three years. Such insurance must provide coverage for, without limitation, the negligent acts of the owner and tenant and their guests or other occupants of the unit for

damage to the general and limited common elements and other units and the personal property of others located therein.

8.2 **Other Insurance Requirements.** Insurance obtained by the Association shall be governed by the following requirements:

(a) All policies shall be written with the State of Oregon or a company licensed to do business in the State of Oregon acceptable to FannieMae which falls into a "B" or better general policyholder's rating or a "6" or better financial performance index rating in Best's Insurance Reports, an "A" or better general policyholder's rating and a financial size category of "VIII" or better in Best's Insurance Reports – International Edition, an "A" or better rating in Demotech's Hazard Insurance Financial Stability Ratings, a "BBBq" qualified solvency ratio or a "BBB" or better claims-paying ability rating in Standard and Poor's Insurer Solvency Review, or a "BBB" or better claims – paying ability in Standard and Poor's International Confidential Rating Service.

(b) Notwithstanding the provisions of Section 8.1 above, there may be named as an insured, on behalf of the Association, the Association's authorized representative, including any trustee with whom the Association may enter into any Insurance Trust Agreement, or any successor to such trustee. Such insurance trustee shall have exclusive authority to negotiate losses under any property or liability insurance policy. Each unit owner appoints the Association, or any insurance trustee or substitute trustee designated by the Association, as attorney-in-fact for the purpose of purchasing and maintaining such insurance including: the collection and appropriate disposition of the proceeds thereof, the negotiation of losses and execution of releases of liability, the execution of all documents, and the performance of all other acts necessary to accomplish such purchase. The Association or insurance trustee shall receive, hold or otherwise properly dispose of any proceeds of insurance in trust for unit owners and their first Mortgage holders, as their interests may appear.

(c) All property insurance policies shall contain a "Special Condominium Endorsement" or its equivalent providing for the following: recognition of any Insurance Trust Agreement, a waiver of the right of subrogation against unit owners individually, that the insurance is not prejudiced by any act or neglect of individual unit owners that is not in the control of such owners collectively, and that the policy is primary in the event the unit owner has other insurance covering the same loss.

(d) For purposes of this article, insurance policies are unacceptable where (i) under the terms of the insurance carrier's charter, bylaws or policy, contributions or assessments may be made against FannieMae, the designee of FannieMae, or the Association or unit owners, or (ii) by the terms of the carrier's charter, bylaws or policy, loss payments are contingent upon action by the carrier's board of directors, policy holders or members, or (iii) policy includes any limiting clauses (other than insurance conditions) that could prevent FannieMae or the owners from collecting insurance proceeds.

(e) All policies required by this article shall provide that they may not be canceled or substantially modified without at least ten (10) days' prior written notice to the Association and to each holder of a first Mortgage which is listed as a scheduled holder of a first Mortgage in the insurance policy. Evidence of insurance shall be issued to each unit owner and Mortgagee upon request.

(f) Each unit owner shall be required to notify the board of directors of all improvements made by the owner to his or her unit, the value of which is in excess of Five Hundred Dollars (\$500). Nothing in this paragraph shall permit an owner to make improvements without first obtaining the approval of the board of directors pursuant to Section 7.2.

(g) Any unit owner who obtains individual insurance policies covering any portion of the property other than such owner's personal property and fixtures shall file a copy of such individual policy or policies with the Association within thirty (30) days after the purchase of such insurance.

8.3 **Optional Provisions.** The board of directors shall make every effort to secure insurance policies that will provide for the following:

(a) To the extent appropriate and available at reasonable cost, the Association shall maintain additional coverages against such other risks as are customarily covered with respect to projects similar in construction, location and use, including but not limited to, host liquor liability, contractual and all-written contract insurance, employer's liability insurance, comprehensive automobile liability insurance, and an endorsement patterned after "use and occupancy" insurance providing relief from monthly assessments while a unit is uninhabitable due to a covered loss.

(b) If reasonably available, the insurance policies shall include Inflation Guard Endorsement, and Construction Code Endorsements (such as a Demolition Cost Endorsement, a Contingent Liability from Operation of Building Laws Endorsement, and an Increased Cost of Construction Endorsement).

(c) Flood Insurance, if the Condominium is in a Special Flood Hazard Area.

(d) If reasonably available, waiver of subrogation by the insurer as to any claims against the board of directors, any unit owner or any guest of a unit owner.

8.4 **FannieMae and GNMA Requirements.** Notwithstanding any other provisions of this article, the Association shall continuously maintain in effect such casualty, flood and liability insurance and a fidelity bond meeting the insurance and fidelity requirements for condominium projects established by FannieMae, the Federal Home Loan Mortgage Corporation, and Government National Mortgage Association, so long as they are a Mortgagee or owner of a unit within the Condominium, except to the extent such coverage is not available or has been waived in writing by FannieMae, the Federal Home Loan Mortgage Corporation, or Government National Mortgage Association. FannieMae, the Federal Home Loan Mortgage Corporation, or their servicers, their successors and assigns, shall be named as a Mortgagee in the Association's policies.

## Article 9

### **AMENDMENTS TO BYLAWS**

9.1 **How Proposed.** Amendments to the bylaws shall be proposed by either a majority of the board of directors or by unit owners holding thirty percent (30%) of the voting rights. The proposed amendment must be reduced to writing and shall be included in the notice of any meeting at which action is to be taken thereon or attached to any request for consent to the amendment.

9.2 **Adoption.** A resolution adopting a proposed amendment may be proposed by either the board of directors or by the unit owners and may be approved by the unit owners at a meeting called for this purpose or by ballot vote. Unit owners not present at the meeting considering such amendment may express their approval in writing or by proxy. Any resolution must be approved by unit owners holding a majority of the voting rights and by Mortgagees to the extent required by the Declaration, except that (a) any provision of these Bylaws that is also contained in the Declaration must be approved by the same voting requirement for amendment of such provision of the Declaration, and (b) any amendment relating to age restrictions, pet restrictions, limitations on the number of persons who may occupy units, or

limitations on the rental or leasing of units must be approved by unit owners holding seventy-five percent (75%) of the voting rights. Declarant's consent shall also be required so long as Declarant owns any of the units in the Condominium. Such consent shall not be required after ten (10) years from the date of conveyance of the first Living Unit to a person other than a successor declarant. Any amendment that would limit or diminish any special Declarant rights established in these Bylaws shall require the written consent of Declarant and any amendment to Sections 3.7, 3.16, 7.7, 9.2 and 10.3 of these Bylaws shall require the written consent of Declarant for a period of ten (10) years after the date of the Organizational and Turnover Meeting described in Section 2.2.

9.3 **Execution and Recording.** An amendment shall not be effective until certified by the chairperson and secretary of the Association as being adopted in accordance with these Bylaws and the provisions of the Oregon Condominium Act and recorded as required by law. Any amendment adopted within five (5) years after the recording of the initial bylaws shall be approved by the Oregon Real Estate Commissioner to the extent required by the Oregon Condominium Act.

## Article 10

### **DISPUTE RESOLUTION**

10.1 **Claims Other than for Defective or Negligent Construction or Condition.** The following provisions of this Section 10.1(a) shall apply to any claim, controversy or dispute by or among Declarant (including members, officers, directors, shareholders and affiliates of Declarant), the Association, the manager or one or more unit owners, or any of them, arising out of or related to the Declaration, these Bylaws or the Condominium, other than claims relating to defective or negligent construction or condition as provided in Section 10.2 below:

(a) **Mediation.**

(1) Except as otherwise provided in this Section 10.1(a), before initiating litigation, arbitration or an administrative proceeding in which the Association and an owner have an adversarial relationship, the party that intends to initiate litigation, arbitration or an administrative proceeding shall offer to use any dispute resolution program available within Multnomah County, Oregon, that is in substantial compliance with the standards and guidelines adopted under ORS 36.175. The written offer must be hand delivered or mailed by certified mail, return receipt requested, to the address, contained in the records of the Association, for the other party.

(2) If the party receiving the offer does not accept the offer within 10 days after receipt by written notice hand delivered or mailed by certified mail, return receipt requested, to the address, contained in the records of the Association, for the other party, the initiating party may commence the litigation, arbitration or the administrative proceeding. The notice of acceptance of the offer to participate in the program must contain the name, address and telephone number of the body administering the dispute resolution program.

(3) If a qualified dispute resolution program exists within Multnomah County, Oregon, and an offer to use the program is not made as required under paragraph (1) of this Section 10.1(a), litigation, arbitration or an administrative proceeding may be stayed for thirty (30) days upon a motion of the noninitiating party. If the litigation, arbitration or administrative action is stayed under this paragraph, both parties shall participate in the dispute resolution process.

(4) Unless a stay has been granted under paragraph (3) of this Section 10.1(a), if the dispute resolution process is not completed within thirty (30) days after receipt of the initial

offer, the initiating party may commence litigation, arbitration or an administrative proceeding without regard to whether the dispute resolution is completed.

(5) Once made, the decision of the court, arbitrator or administrative body arising from litigation, arbitration or an administrative proceeding may not be set aside on the grounds that an offer to use a dispute resolution program was not made.

(6) The requirements of this Section 10.1(a) do not apply to circumstances in which irreparable harm to a party will occur due to delay or to litigation, arbitration or an administrative proceeding initiated to collect assessments, other than assessments attributable to fines.

(b) **Arbitration.** Any such claim, controversy or dispute shall be first subject to mediation as provided in Section 10.1(a) above or otherwise, and, if not timely settled by mediation, resolved by arbitration in accordance with this Section 10.3 below. The decision and award of the arbitrator shall be final, binding and nonappealable.

(c) **Excluded Matters.** Notwithstanding the foregoing, the following matters shall not be subject to mediation or arbitration under this Section 10.1 (but shall be subject to the applicable provisions of Section 10.1(d) below): (i) actions relating to the collection of fees, assessments, fines and other charges imposed or levied by the Association (other than disputes as to the validity or amount of such fees, assessments, fines or charges, which disputes shall be subject to mediation/arbitration as provided above), and (ii) actions to enforce any order, decision or award rendered by arbitration pursuant to Section 10.3. The filing of a lis pendens or the application to any court for the issuance of any provisional process or similar remedy described in the Oregon or Federal Rules of Civil Procedure shall not constitute a waiver of the right or duty to utilize the procedures specified in this Section 10.1.

(d) **Costs and Attorneys' Fees.** The fees of any mediator and the costs of mediation shall be divided and paid equally by the parties. Each party shall pay its own attorneys' fees and costs in connection with any mediation. The fees of any arbitrator and the costs of arbitration shall be paid by the nonprevailing party or parties; if none, such fees and costs shall be divided and paid equally by the parties. Except as otherwise provided in Section 10.2(e) below, should any suit, action or arbitration be commenced in connection with any dispute related to or arising out of the Declaration or these Bylaws, to obtain a judicial construction of any provision of the Declaration or these Bylaws, to rescind the Declaration or these Bylaws or to enforce or collect any judgment or decree of any court or any award obtained during arbitration, the prevailing party shall be entitled to recover its costs and disbursements, together with such investigation, expert witness and attorneys' fees incurred in connection with such dispute, as the court or arbitrator may adjudge reasonable, at trial, in the arbitration, upon any motion for reconsideration, upon petition for review, and on any appeal of such suit, action or arbitration proceeding. The determination of who is the prevailing party and the amount of reasonable attorneys' fees to be paid to the prevailing party shall be decided by the arbitrator (with respect to attorneys' fees incurred prior to and during the arbitration proceeding) and by the court or courts, including any appellate or review court, in which such matter is tried, heard or decided, including a court that hears a request to compel or enjoin arbitration or that hears exceptions made to an arbitration award submitted to it for confirmation as a judgment (with respect to attorneys' fees incurred in such proceedings).

10.2 **Claims for Negligent or Defective Construction or Condition.** The following alternative dispute resolution procedures shall apply to any claim by the Association or any unit owner against Declarant or any contractor, subcontractor, supplier, consultant or design professional of every tier performing any work or services in connection with the Condominium, and their agents, brokers, successors, employees, affiliates, representatives, officers, directors and members, and their insurers and re-insurers, related to the design, construction or condition of the Condominium, including, but not

limited to, claims for defective or negligent construction or design or failure to disclose a defective condition.

(a) **Initial Dispute Resolution Procedures.** In the event of a claim for a construction defect governed by ORS 701.550 to 701.595, the parties shall first comply with the provisions contained therein. In the event the claim is not for a construction defect governed by such provisions, but relates to a claimed defect in the condition of the project, the parties shall follow the same procedures as set forth in such provisions, except that the notice of defect shall include a statement of the basis upon which the recipient is claimed to be liable for the defect. Compliance with the procedures contained in this Section 10.2(a) shall be a condition precedent to mediation, arbitration or litigation of any such Claims.

(b) **Mediation.** If the initial dispute resolution proceedings under Section 10.2(a) do not resolve the claims, the parties shall then engage in mediation to resolve the claims. The fees of any mediator and the costs of mediation shall be divided and paid equally by the parties. Each party shall pay its own attorneys' fees and costs in connection with any mediation. Completion of the mediation process under this section shall be a condition precedent to the filing of any arbitration or litigation proceedings or any claims relating to the matter with the Oregon Construction Contractors Board, and the Association and unit owners waive any right to file any such claims if the Association and unit owners have not fully complied with this Section 10.2(b). The mediation shall be conducted in accordance with the following procedures:

(1) Within sixty (60) days after completion of the proceedings under Section 10.2(a) and delivery of a demand for mediation by one of the parties to the other parties, the parties shall agree upon a neutral mediator. If the parties are unable to agree on a mediator within that period, upon application of any party, the Presiding Judge of the Circuit Court of Multnomah County, Oregon, shall designate the mediator.

(2) Within sixty (60) days after delivery of the demand for mediation, the parties shall exchange with each other all inspection and consultant's reports in their possession pertaining to the claims.

(3) The parties shall have ninety (90) days after exchanging reports in which to perform additional inspections. Any additional reports resulting from such inspections shall be furnished to the other parties prior to mediation.

(4) The mediation shall be conducted after completing parts (1) and (3) above, but within one hundred eighty (180) days following delivery of the demand for mediation. The mediator may elect to adjourn the mediation to additional sessions if the mediator determines that further sessions would be beneficial in resolving the disputes.

(5) Each party shall send to the mediation a representative with authority to settle the dispute and will attempt in good faith to resolve all disputes in the mediation.

(6) Any settlement agreed upon in mediation shall be documented and executed within 60 days following completion of the mediation.

(c) **Arbitration.** All claims that have not been resolved by mediation shall be resolved by arbitration in accordance with Section 10.3 below. The decision and award of the arbitrator shall be final, binding and nonappealable.



(d) **Third Parties.** Upon demand by any party, claims between or among the parties and third parties shall be submitted in a single, consolidated arbitration. Notwithstanding the provisions of Section 10.2(c) above, in the event any claim involves a claim by either party against a third party who is not required to and does not voluntarily agree to submit such claim to arbitration, then either party may elect to have the claim and the third party claim determined by a court of law in a consolidated proceeding, rather than by arbitration. In such case, the parties waive trial by jury and agree that the matter shall be determined by a judge sitting without a jury.

(e) **Attorney Fees.** In the event of any claim determined by arbitration or by a court of law under Sections 10.2(c) or 10.2(d) above, each party shall bear their own costs, including, without limitation, filing fees, attorney's fees, investigation expenses, consultant's fees and expert's fees. The other costs of arbitration and other court costs shall be divided and paid equally by the parties. To the extent permitted by law, statutory attorney's fees under the Unlawful Trade Practices Act or any other applicable statute are hereby waived.

(f) **Confidentiality.** The parties shall keep all discussions of disputes, settlements and arbitration awards and decisions confidential and shall not disclose any such information, whether directly or indirectly, to any third parties other than their attorneys and consultants, unless compelled to do so by an order of a court of competent jurisdiction. In the event of a breach of this confidentiality obligation, the other party shall be entitled to seek and obtain any and all equitable remedies, including injunctive relief and specific performance, and the breaching party waives any claim or defense that the other party has an adequate remedy at law for any such breach, and such party shall not be required to post any bond or other security in connection with any such equitable relief.

(g) **Time Periods within which Claims must be Asserted.** Any claims under this Section 10.2, including, without limitation allegations of property damage or personal injury claims arising out of fungus, spores, or mold, any water intrusion or dampness, or otherwise, regardless of the legal theory or basis of alleged causation, including but not limited to, negligence, professional errors or omissions, strict liability, breach of contract, or non-statutory warranty, must be commenced under Section 10.2(a) above within ninety (90) days after the date the Association or the unit owner knew or reasonably should have known of facts sufficient to put them on notice of the claim, **or if earlier**, with respect to the unit and related limited common elements, by no later than the first anniversary of the closing date of the sale of the unit to the first purchaser or, with respect to the general common elements, within ninety (90) days after the date of the Turnover Meeting as described in Section 2.2 of these Bylaws. Any arbitration or litigation based upon such claims must be instituted within ninety (90) days after completion of the mediation proceedings under Section 10.2(b), or if shorter, the applicable statute of limitations. Any and all such claims not brought within these time periods will be deemed time barred, regardless of when the Association or unit owners actually discovered the alleged basis for the claim.

10.3 **Arbitration.** Any arbitration under these Bylaws shall be conducted in Portland, Oregon, or such other location as may be agreed upon by the parties, pursuant to the arbitration statutes of the State of Oregon and any arbitration award may be enforced by any court with jurisdiction. Filing for arbitration shall be treated the same as filing in court for purposes of meeting any applicable statute of limitations or for purposes of filing a notice of pending action ("lis pendens").

(a) **Selection of Arbitrator.** The arbitration shall be conducted by a single arbitrator selected by mutual agreement of the parties. The arbitrator selected shall be neutral and unbiased, except to the extent the arbitrator's prior relationship with any party is fully disclosed and consented to by the other party or parties. If the parties are unable to agree upon the arbitrator within thirty (30) days after a party's demand for arbitration, upon application of any party, the Presiding Judge of the Circuit Court of Multnomah County, Oregon shall designate the arbitrator.

(b) **Consolidated Arbitration.** Upon demand by any party, claims between or among the parties and third parties shall be submitted in a single, consolidated arbitration. Notwithstanding the provisions of Section 10.2(c), in the event any claim, controversy or dispute involves a claim by either party against a third party who is not required to and does not voluntarily agree to submit such claim to arbitration, then either party may elect to have the matter determined by a court of law in a consolidated proceeding, rather than by arbitration. In such case, the parties hereby waive trial by jury and agree that the matter shall be determined by a judge sitting without a jury.

(c) **Discovery.** The parties to the arbitration shall be entitled to such discovery as would be available to them in an action in Multnomah County Circuit Court. The arbitrator shall have all of the authority of the Court incidental to such discovery, including without limitation authority to issue orders to produce documents or other materials, to issue orders to appear and submit to deposition, and to impose appropriate sanctions including without limitation award against a party for failure to comply with any order.

(d) **Evidence.** The parties to the arbitration may offer such evidence as they desire and shall produce such additional evidence as the arbitrator may deem necessary for an understanding and determination of the dispute. The arbitrator shall determine the admissibility of the evidence offered. All evidence shall be taken in the presence of the arbitrator and all of the parties, except where any of the parties is absent, in default or has waived its right to be present.

10.4 **Survival.** The mediation and arbitration agreements set forth in this Article 10 shall survive the transfer by any party of its interest or involvement in the Condominium and any unit therein and the termination of the Declaration or these Bylaws.

## Article 11

### **MISCELLANEOUS**

11.1 **Notices.** All notices to the Association or to the board of directors shall be sent care of the manager, or if there is no manager, to the principal office of the Association or to such other address as the board of directors may designate from time to time. All notices to any unit owner shall be sent to such address as may have been designated by such owner from time to time, in writing, to the board of directors, or, if no address has been designated, then to the owner's unit.

11.2 **Waiver.** No restriction, condition, obligation, or provision contained in these Bylaws shall be deemed to have been abrogated or waived by reason of any failure to enforce the same, irrespective of the number of violations or breaches thereof which may occur.

11.3 **Action Without a Meeting.** Any action that the Oregon Condominium Act, the Declaration or these Bylaws require or permit the owners or directors to take at a meeting or ballot meeting may be taken without a meeting or ballot meeting if a consent in writing setting forth the action so taken is signed by all of the owners or directors entitled to vote on the matter. The consent, which shall have the same effect as a unanimous vote of the owners or directors, shall be filed in the records of minutes of the Association.

11.4 **Invalidity; Number; Captions.** The invalidity of any part of these Bylaws shall not impair or affect in any manner the validity, enforceability or effect of the balance of these Bylaws. As used in these Bylaws, the singular shall include the plural, and the plural the singular. The masculine and neuter shall each include the masculine, feminine and neuter, as the context requires. All captions are

intended solely for convenience of reference and shall in no way limit any of the provisions of these Bylaws.

11.5 **Conflicts.** These Bylaws are intended to comply with the Oregon Condominium Act and the Declaration. In case of any irreconcilable conflict, such statute and document shall control over these Bylaws or any rules and regulations adopted hereunder.

DATED this 17th day of March, 2006.

**PORTLAND CENTER INVESTORS LLC**, a Delaware limited liability company

By: Portland Center Mezzanine LLC, a Delaware limited liability company, Manager

By: Portland Center Holding Company LLC, a Delaware limited liability company, Manager

By: S&T-WDD Development, LLC, an Oregon limited liability company, Manager

By: Williams & Dame Development, Inc., an Oregon corporation, Co-Manager

By: S&T Development- Portland Center, LLC, an Oregon limited liability company, Co-Manager

By: ~~Reliance Development, Inc., an Oregon corporation, Member~~

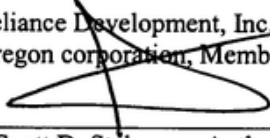
By:   
Scott D. Stehman, Authorized Signer

75  
31

Multnomah County Official Records  
Cindy Swick, Deputy Clerk 2008-045800

AFTER RECORDING, RETURN TO:



\$36.00

Howard M. Feuerstein, Esq.  
Stoel Rives LLP  
900 SW Fifth Avenue, Suite 2600  
Portland, OR 97204

00299415200800458000030033 03/26/2008 02:10:16 PM  
1R-AMMODCCR Cnt=1 Stn=27 ATVLM  
\$15.00 \$5.00 \$11.00 \$5.00

**FIRST AMENDMENT TO MASTER DECLARATION OF  
COVENANTS, CONDITIONS, RESTRICTIONS  
AND EASEMENTS FOR HARRISON CENTER**

**THIS FIRST AMENDMENT TO MASTER DECLARATION OF COVENANTS,  
CONDITIONS, RESTRICTIONS AND EASEMENTS FOR HARRISON CENTER** is  
made and executed this 26<sup>th</sup> day of March, 2008, by **HARRISON CENTER MASTER  
ASSOCIATION**, an Oregon nonprofit corporation (“**Master Association**”).

**RECITALS**

- A. Portland Center Investors LLC, recorded that certain Master Declaration of Covenants, Conditions, Restrictions and Easements for Harrison Center on April 18, 2006 as Document No. 2006-070734 in the Official Records of Multnomah County, Oregon (the “**Master Declaration**”).
- B. The Master Declaration contemplated that all three Apartment Projects within the Harrison Center would be converted to separate condominiums. Two of the three Apartment Projects have been converted to condominiums known as the “Harrison West Condominiums” and “Harrison East Condominiums.” The remaining south tower of the Harrison Center has not been converted to condominium ownership and remains an Apartment Project (the “**South Tower**”).
- C. The Master Declaration created the Master Association to oversee the implementation and enforcement of the Master Declaration as to all of the Harrison Center.
- D. The Master Association now wishes to amend the Master Declaration to clarify that only certain elements of the South Tower shall be Community Facilities, as such term is defined in the Master Declaration.
- E. All terms not herein defined shall have the same meaning as defined in the Master Declaration.

**NOW, THEREFORE**, the Master Association hereby amends the Master Declaration as set forth below:

1. **SOUTH TOWER**. Attached as Exhibit A to this Amendment is a depiction of the South Tower and its grounds. As shown on Exhibit A, only those cross-hatched portions of the grounds of the South Tower shall be Community Facilities for purposes of the Master

3

450209 COMM.

Chicago Title

Declaration. All remaining portions of the South Tower and grounds shall be private and shall not be encumbered by the Master Declaration.

2. **EFFECT OF AMENDMENT.** Except as specifically amended herein, the Master Declaration shall otherwise remain unchanged.

IN WITNESS WHEREOF, the Master Association has caused this Amendment to be executed as of the day and year first set forth above.

HARRISON CENTER MASTER ASSOCIATION,  
an Oregon nonprofit corporation

By: [Signature]  
Scott D. Stehman President

By: [Signature]  
David W. Gifford Secretary

**Certification**

The undersigned President and Secretary of **HARRISON CENTER MASTER ASSOCIATION**, an Oregon nonprofit corporation, hereby certifies that the within **FIRST AMENDMENT TO MASTER DECLARATION OF COVENANTS, CONDITIONS, RESTRICTIONS AND EASEMENTS FOR HARRISON CENTER** has been approved and adopted in accordance with the Declaration and applicable law.

By: [Signature]  
Scott D. Stehman President

By: [Signature]  
David W. Gifford Secretary

STATE OF Oregon )  
County of Multnomah )ss.

This instrument was acknowledged before me this 25 day of March, 2008, by Scott D. Stehman and David W. Gifford, President and Secretary, respectively, of Harrison Center Master Association, an Oregon nonprofit corporation, on its behalf.

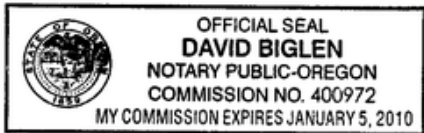

[Signature]  
Notary Public for Oregon  
My commission expires: 1/5/2010  
Commission No.: 400972

# EXHIBIT A

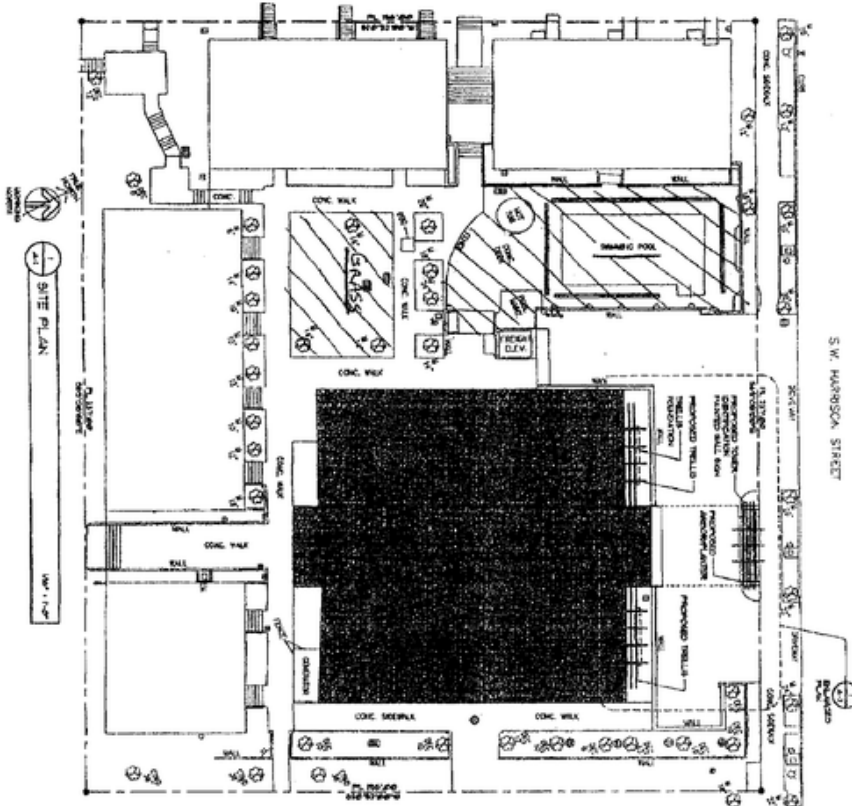

KEYED NOTES

GENERAL NOTES  
 1. CONTINUATION TO SHEET A-1, ADDITIONAL PLANS  
 2. INFORMATION FROM SO CONTRACTORS

Project  
 Steel  
 THIN  
 SHEET  
 A-1  
 OF  
 DATE 9-15-77

HARRISON SOUTH  
 PORTLAND CENTER  
 TOWER 222  
 PORTLAND, OR  
 97201

STEVEN FORSON  
 ARCHITECT/LLC  
 5150 LANBURN AVE  
 SEASIDE OREGON 97138  
 503-743-3333  
 503-743-1800  
 FAX (503)288-0969  
 steel is architecture

